

User's Manual for Insulation Test Device / 3304

Last update: 20.11.2004

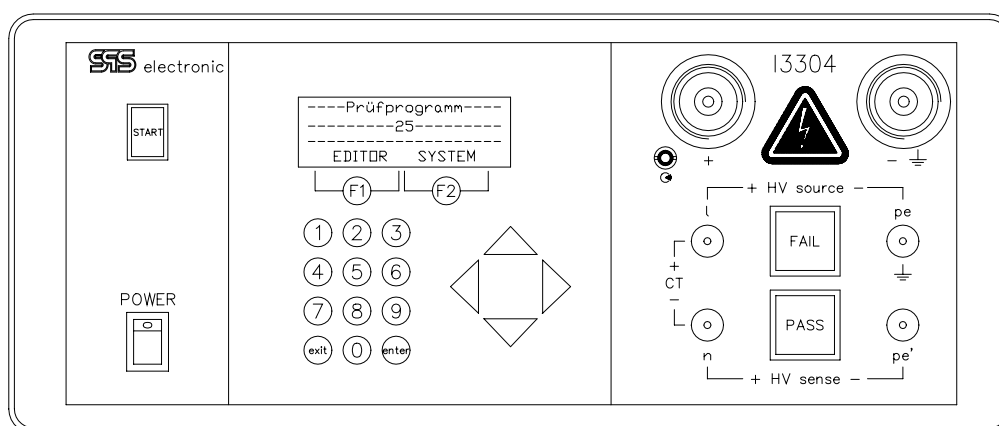

Series:	I 3304
Serial number:	
Constructed in:	

SPS electronic GmbH
Blätterracker 18, 74523 Schwäbisch Hall

Phone: +49 (0) 79 07 878 - 0

Fax: +49 (0) 79 07 878 - 10

e-mail: info@spselectronic.com

Internet: www.spselectronic.com

Contents

1	General Information	5
1.1	Information on this manual	5
1.2	Requirements for operation of device	7
1.3	Service	8
1.4	General instructions and regulations on safety	9
2	Hardware Description	12
2.1	Functions	12
2.2	Technical data	13
2.3	Design and functions	15
2.3.1	Front panel	15
2.3.2	Rear panel	16
2.4	Expansions, options and accessories	17
2.4.1	Device versions	17
2.4.2	Options	17
2.4.3	Accessories	17
3	Operation	18
3.1	Start of operation	18
3.1.1	Requirements	18
3.1.2	Installation of test station	18
3.1.3	Connecting DUT	19
3.2	Changing of program settings	20
3.2.1	General notes to manual programming	20
3.2.2	Programming individual test programs	21
3.2.3	Changing of system parameters	22
3.2.4	Changing of test parameters	25
3.3	Executing tests	26
3.3.1	Continuity test	27
3.3.2	Insulation test	28
3.3.3	High voltage test DC	31
3.4	Remote control via RS 232	33
3.4.1	Syntax	33
3.4.2	Global commands	34
3.4.3	Local commands	35
3.4.4	Status and error parameters	38
3.5	Error display	41
3.5.1	Error display	41
3.5.2	Error messages on LC display	41

3.6 Maintenance and function check	42
3.6.1 Maintenance	42
3.6.2 Function check.....	42
Appendix	43
A Special functions	43
B Interface Configuration.....	45
C Information on programming and program run	48
D Protocolling of test results.....	49
E Terms of warranty	51

1 General Information

1.1 Information on this manual

This operating manual is part of the technical documentation for the insulation test device I 3304 of SPS electronic GmbH.

In this operating manual you will find all the information on how to operate this tester properly, safely and economically, how to prevent danger, how to reduce repair costs and downtimes as well as how to increase the tester's service life.

Should you, while reading this manual, find misprints, information you don't understand or wrong information, please don't hesitate to inform SPS electronic GmbH respectively.

Contents

In this operating manual you will find three chapters and one appendix. You will find additional information in the appendix.

The headline will show you which chapter you are reading.

The bottom line will show you the type of device in the middle, and on the right-hand side the page number.

Piktograms and symbols

- **Warnings** are symbolized by warning triangles with danger symbol, they warn of possible personal injury and/or damage to property.



General Warning



Dangerous electric current or voltage

- **Pointers** are symbolized by the information pictogram and give recommendations or additional information.



You can order all of these accessories directly from SPS electronic GmbH.

- **Continuations** of coherent sections on the next page are symbolized by the symbol  in the lower right corner of a page.



... **PIKTOGRAMS AND SYMBOLS**

More than one operation is symbolized by ●

example: ● continuity test (CT-test)
● insulation test (IS-Test)

Consecutive operations are numbered step by step.

example: 1. switch on power switch
2. press key F2 (< Prgrnr >)

results are symbolized by ⇨

example: ⇨ LC-display shows current program number.

1.2 Requirements for operation of device

1.2.1 Operating specifications

The tester must be reliable and perform properly.

Only authorized personnel, e.g. electricians and/or electrical engineers who have read and fully understood this manual, are allowed to operate a tester.

Operation of the tester is not allowed if:

- the tester is not assembled, operated, maintained and serviced according to this manual or as recommended by *SPS electronic GmbH* respectively
- it is modified and/or repaired without authorization
- it is disassembled and/or safety equipment is disregarded
- components, tools, auxiliary equipment and/or means, and/or fuel, coolants and lubricants which have not been approved or recommended by *SPS electronic GmbH* are being used
- replacement parts which are not original *SPS electronic GmbH* ones or which are not supplied by a supplier recommended by *SPS electronic GmbH* are being built in

1.2.2 Product liability

The insulation test device I 3304 is manufactured, adjusted/calibrated and tested according to the latest and approved technical and safety regulations.

The device complies in design and in the selection of component parts and accessories with the terms agreed upon in the order confirmation.

SPS electronic GmbH will be liable for errors or failures/ommissions to the extent of the obligations guaranteed in the order confirmation.

The terms of guarantee and liability of the *SPS electronic GmbH* sales and delivery conditions are applicable.

The contents of this operating manual complies with the condition of this tester at time of issue of this manual.

SPS electronic GmbH products are subject to change due to continuous development and improvement.

No liability claims can be made on the grounds of the contents of this manual (e.g. data, specifications, diagrams/charts, misprints, etc.).

Errors and omissions excepted!

***SPS electronic GmbH* will only be liable if the tester I 3304 has been operated or used properly (pl. see 1.2.1).
If the testers are not operated or used properly the operator will be solely responsible for endangering life and limb of the user or a third party and for damaging the device and other property as well!**



1.3 Service

SPS electronic GmbH will gladly be at your disposal if you need to find solutions to special problems, for doing repairs, for maintaining your equipment or for necessary alterations, in a nutshell for everything this manual doesn't tell you.

Please contact us via any of the below communication possibilities:

SPS electronic GmbH
Blätteräcker 18
74523 Schwäbisch Hall
Phone: (0 79 07) 8 78 - 29
Fax: (0 79 07) 8 78 - 22
e-mail: service@spselectronic.com
Internet: www.spselectronic.com

1.4 General instructions and regulations on safety

The insulation test device *I 3304* is produced in compliance with the technical requirements at time of delivery.

Nevertheless, there can occur dangerous situations in connection with the tester if not operated properly by trained personnel or if used inexpertly or against regulations.

Further to this manual the generally applicable legal regulations and other binding directives in regard to safety on the job, to accident prevention and to environmental protection must be observed.



1.4.1 User's responsibility

- Only when **performing properly and reliably** the device must be operated (pl. see 1.2.1)
- Equipment for protection and safety, locking devices and couplings, etc. must be checked by a technical expert at least once a year.
The test results must be recorded in a **test certificate** and they must be kept in a file.
- **Instruction is compulsory** when operating, in any way, a machine or an equipment which may endanger the health and/or life of persons.
People operating in any way an *I 3304* must acknowledge with their signature that they read and understood this operation manual, especially the paragraph on instructions and regulations on safety.
- Dangerous areas resulting from **incorporating** the tester into a system or device must be located and secured by the user/operator.
When setting up or installing devices, systems or production facilities of different manufacturers or suppliers as well as after modifications by company or service personnel whereby electrical equipment is manipulated, the operator must, before starting the operation, conduct a precise check according to the accident prevention regulations VBG 4 and in compliance with the appropriate electro-technical regulations respectively.

1.4.2 Personnel

- Operating manual, instructions and regulations are an essential part of the tester and must, at all times, be within easy reach of all the persons operating in any way an *I 3304* tester.
- Before starting to operate an *I 3304* tester questions concerning their proper operation have to be answered by or discussed with the personnel in charge.
- Any operation in connection with an *I 3304* tester shall only be executed by personnel trained respectively, e.g. electricians and/or technical engineers and who have been authorized by the operator/user to do so.
- Trainees and persons under the age of 18 shall only operate an *I 3304* when supervised by trained personnel, like electricians and/or technical engineers.
- Adjustments/calibrations, maintenance and inspections have to be executed in time and according to specifications.

1.4.3 Safety equipment

The insulation test devices *I 3304* are, for the safety of the operating personnel, equipped with below safety equipment:

- safety current limiting for insulation test and high voltage test acc. VDE 104 (< 12 mA DC)

1.4.4 Information on additional literature

The professional associations and trade unions have, for the safety of persons, published below literature:

- VBG 1 Accident Prevention – General Regulations
- VBG 4 Accident Prevention – Electrical Systems and Production Facilities
- VBG 109 Accident Prevention – First Aid
- DIN VDE 0104 Installation and Operation of Electrical Systems
- DIN VDE 0106 part 1 Protection against Electric Shock
Classification of Electrical and Electronical Production Facilities
- DIN 40 008 part 3 Safety Labels for Electrical Engineering;
Danger Signs and Supplementary Labels
- DIN 40 050 IP-Protective Systems; Contact and/or Foreign Matter, and Water
Protection for Electrical Production Facilities
- DIN VDE 0100 Installation of Power Plants up to 1000 V



This literature will give you additional information and it is an essential part of this operating manual. Their observance therefore is mandatory!



You can buy or order literature giving information on above instructions and regulations at or from:

- **on laws and regulations**

at your book store/dealer

or

from Carl Heymanns Verlag KG, Luxemburger Straße 449, D-50939 Köln

- **on accident prevention regulations**

from a professional/trade association

or

from Carl Heymanns Verlag KG, Luxemburger Straße 449, D-50939 Köln

- **directives, safety regulations and respective leaflets of professional/trade associations**

from a professional/trade association

or

from Carl Heymanns Verlag KG, Luxemburger Straße 449, D-50939 Köln

- **DIN-Standards**

from Beuth Verlag GmbH, Burggrafenstraße 6, D-10787 Berlin

- **VDE-Regulations**

from VDE-Verlag GmbH, Bismarckstraße 33, D-10625 Berlin

2 Hardware Description

2.1 Functions

The insulation test device I 3304 has been designed for use in automatic testing systems. All test and control signals are led out on the rear side of the testing set. In addition, a manual operation is possible over the control elements on the front plate.

The insulation test device I 3304 is available either with 2-wire- or 4-wire-measurement technique. When powering the device on, the device version is shown in the LC-display.

With the insulation test device I 3304, the insulation resistance of electrical devices and systems can be tested according to standardized test provisions (EN, IEC, VDE etc..). All energized lines are tested against the protective wire of the device under test.

The following diagram shows the princip of insulation test:

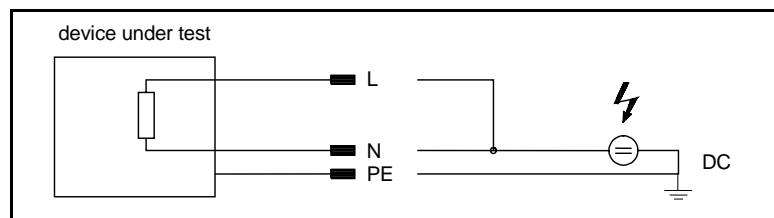

basic circuit of insulation test

The guidelines for insulation measurements are specified in VDE 0413, part 1. Six of these guidelines are particularly worth mentioning:

- The measurement has to take place with DC voltage of small ripples.
- DC voltage must have at least the same value of the rated voltage of the network which can be checked.
- The insulation resistance may not fall below 1000 Ohm/V.
- The error of the indicated measuring range may not exceed $\pm 30\%$.
- The rated current must amount to at least 1 mA.
- The links must be contact-voltage-proof.

The error of $\pm 30\%$ appears as very high, however this is given by the selected measurement principle of almost all manufacturers. With the device I 3304, the ripples are held by an electronic stabilization to very small values ($< 1\%$). The short circuit current amounts to 6 mA and is thus harmless.



The insulation test device I 3304 is not potential-free! (HV⁻ is grounded)



The discharging of the DUT to $U < 50$ V, necessary after the test, needs time. The warning lights PASS or FAIL light up only after discharging. With DUTs of very high capacity this takes max. 5 seconds; generally the discharging process takes one or two seconds.

2.2 Technical data

Dimensions and weight			
width / depth/ height	approx.. 360 / 330 / 150 mm		
weight	60 N (6,0 kg)		
Environmental conditions			
temperature	operating: 15 °C – 40 °C non-operating: 5 °C – 60 °C		
humidity	max. 70% (not condensating)		
Connection specifications			
power supply	230 V / 50 Hz (115 V / 60 Hz optional)		
power consumption	max. 500 VA		
Operating specifications			
Continuity test			
- test voltage	24V DC \pm 2%		
- thresholds	programmable		
- measuring range	up to 999 mA DC (short-circuit)		
	range 0 up to 1 A	resolution 1 mA	precision 1,5% of max. value \pm 1 mA
Insulation test			
- test voltage	range 1: 40 - 400 V DC \pm 1,5% , programmable range 2: 400 - 600 V DC \pm 1,5% , programmable range 3: 600 - 6000 V DC \pm 1,5% , programmable		
- thresholds	programmable		
- short circuit current	< 6 mA DC		
- measuring range	<i>depends on test voltage, see diagrams on next page</i>		
High voltage test DC			
- test voltage	range 1: 40 - 400 V DC \pm 1,5% , programmable range 2: 400 - 600 V DC \pm 1,5% , programmable range 3: 600 - 6000 V DC \pm 1,5% , programmable		
- thresholds	programmable		
- short-circuit current	< 6 mA DC		
- measuring range	range 0,1 up to 5 mA 0,1 up to 2 mA	resolution 0,01 mA	precision 1,5% of max. value \pm 0,01 mA
Additional features			
<ul style="list-style-type: none"> ● 14" / 3 HU housing with integrated keyboard and LC display ● RS 232 – interface for printer connection or remote control ● menu-driven programming (up to 100 test programs programmable) ● continuity test 24 V DC max 999 mA ● safety current limited voltage source for insulation and high voltage test DC 			

Measuring ranges of Insulation Test

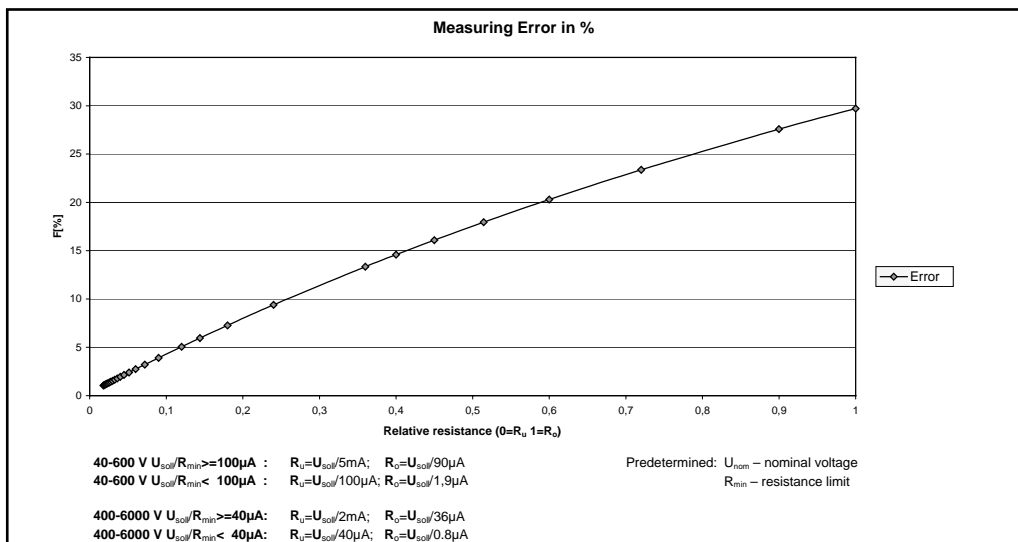
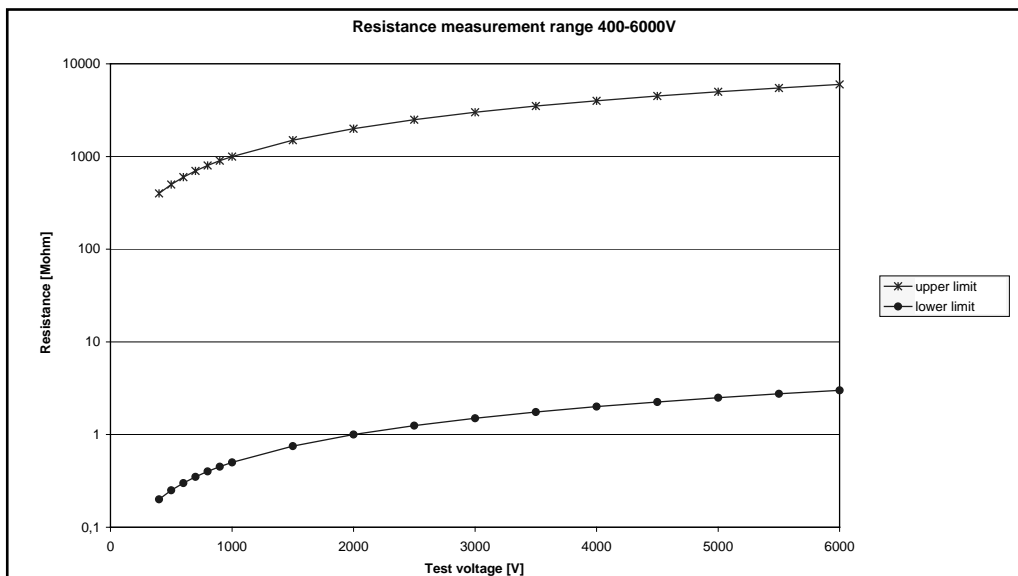
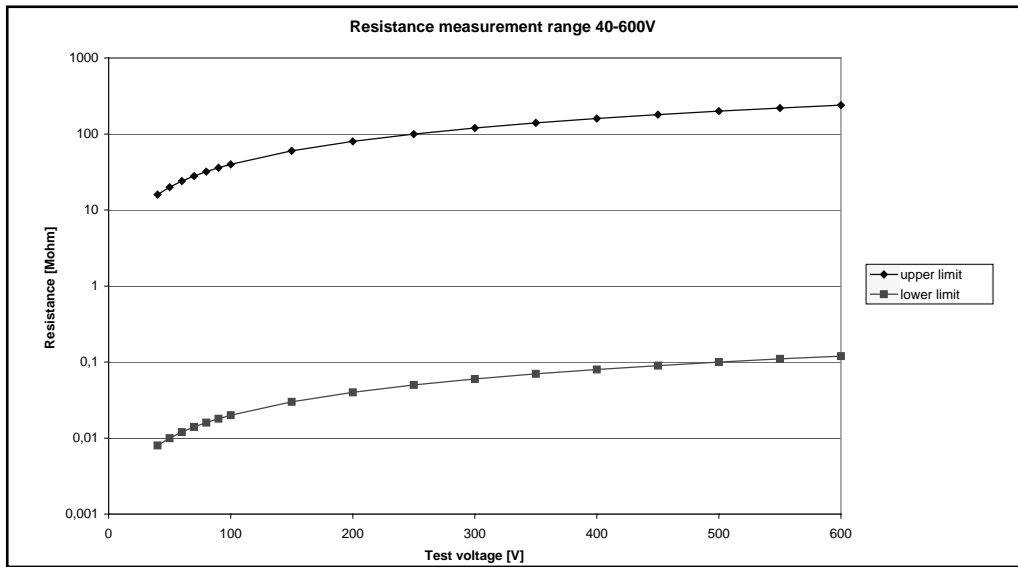

2.3 Design and functions

2.3.1 Front panel

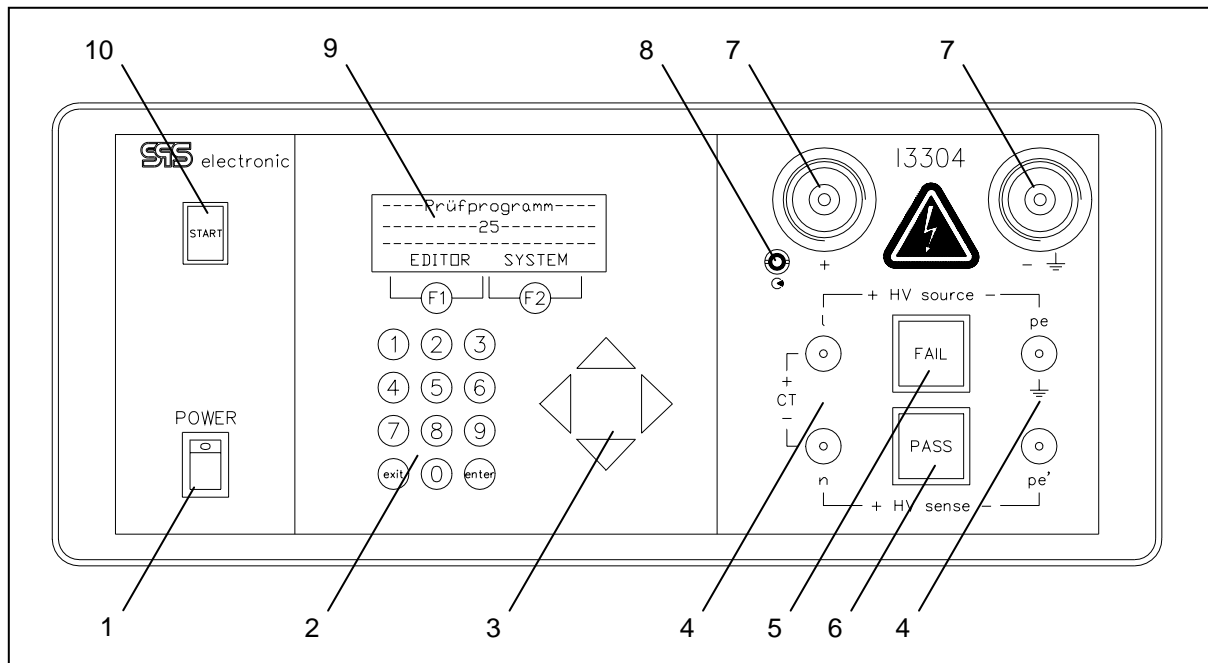

Front panel / 3304

- 1.) Power switch
- 2.) Number keys for inputs, exit key (= F1), enter key (= F2)
- 3.) Cursor keys for selections
- 4.) DUT connection sockets
- 5.) Red light *FAIL*: lights up if test failed or DUT did not pass test
- 6.) Green light *PASS*: lights up if DUT passed test
- 7.) Connection sockets for HV-pistols
- 8.) Connection socket for START-key of HV-pistol
- 9.) LC-display
- 10.) Key START

2.3.2 Rear panel

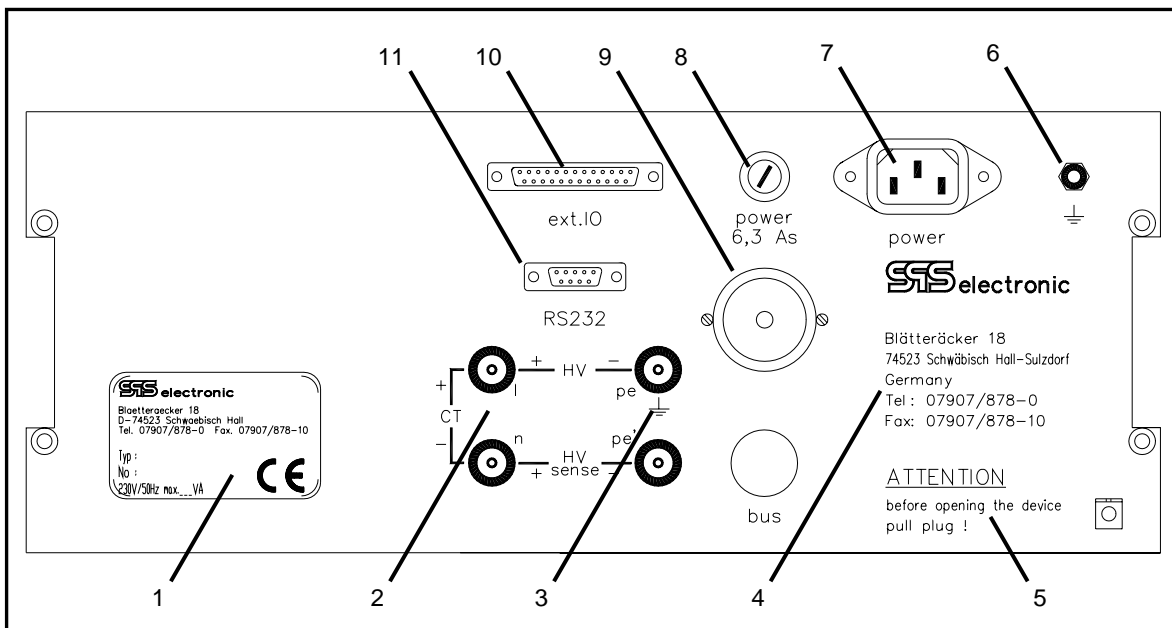

Rear panel of I 3304

- 1 type label with
 - address of manufacturer
 - device designation (type)
 - serial number (no)
 - max. power consumption at 230 V / 50 Hz in VA
 - CE mark
- 2 DUT connector
- 3 DUT connector
- 4 address of manufacturer
- 5 safety instruction:
 - ATTENTION*
 - before opening device*
 - pull plug!*
- 6 protective earth
- 7 cold appliance socket for power cable
- 8 main fuse
- 9 buzzer
- 10 I/O – outputs for connection of i.e. external control desk
- 11 RS232 - interface for connection of printer or PC

2.4 Expansions, options and accessories

2.4.1 Device versions

- Insulation tester I 3304 S
 - Same as I 3304D, but with 4-wire-technique
- Insulation tester I 3304 L
 - Plug-in 19" / 4 HU
 - Same as I 3304D, but with 4-wire-technique

2.4.2 Options

- Protocol acc. to ISO 9000
- power supply 115 V / 60 Hz
- specific connector for USA, GB, F, I and CH

2.4.3 Accessories

- High voltage pistol SP 02
 - Connecting cable 5m
 - without Start-key
- High voltage pistol SP 03
 - Connecting cable 5m
 - with Start-key
- Setting-up grasp AG 14
 - for devices 14" / 3HE
- Printer DK 23
 - Type: Epson LX300 or similar
 - B/W-matrix printer, plain paper A4, endless form/single sheet
 - RS 232- and parallel interface
 - Power supply 230 V / 50 Hz
 - incl. connection cable
- Test dummy D 9708
 - to verify the correct function of testing device
 - for HV-, IS-, PE- and AI-Test
- PC-Software 3332-LINK
 - for WINDOWS 95/98/2000/NT
 - PC-software 32bit, network capable
 - programming the testing device by PC
 - Reading the test programmes out of the testing device, and edit or archive them on a PC
- Remote control software 3332 DAT
 - PC-Software 32bit, network capable
 - creation of testing programs, protocols, and statistics
 - test- and measurement data are stored along with all information about DUT
 - possibility of connection to a database (ACCESS)
 - for WINDOWS 95/98/2000/NT

3 Operation

3.1 Start of operation

3.1.1 Requirements



The tester / 3304 as well as all the electrical connections and cables must function and perform properly and reliably.

Only authorized personnel, like electricians or electrical engineers or personnel supervised by same shall operate a tester.

The generally applicable safety regulations (pl. see paragraph 1.4) and the generally valid legal regulations as well as any other applicable and valid regulations as to safety on-the-job, accident prevention and environmental protection have to be observed and persons working in such an area, have to be instructed respectively.



There is danger of life caused by electric current or voltage if not dealing properly with electrical systems!

3.1.2 Installation of test station

1. choose a level, clean and dry base for your test station
2. if necessary, turn off power switch (key switch) at tester
3. plug power cable at the back of tester into cold appliance socket and connect to power supply
4. if required connect external devices to interfaces:
 - operating desk to I/O interface at the back *and/or*
 - PC or printer to RS 232 interface at the back

3.1.3 Connecting DUT

Connecting scheme I 3304 with 2-wire-technique

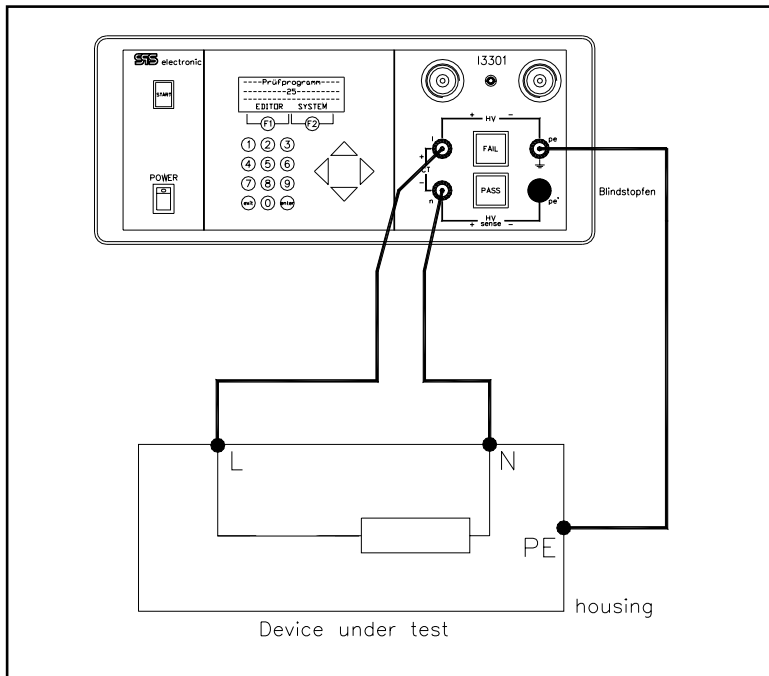

Remark:
HV⁻ is grounded!

Connecting scheme I 3304 with 4-wire-technique

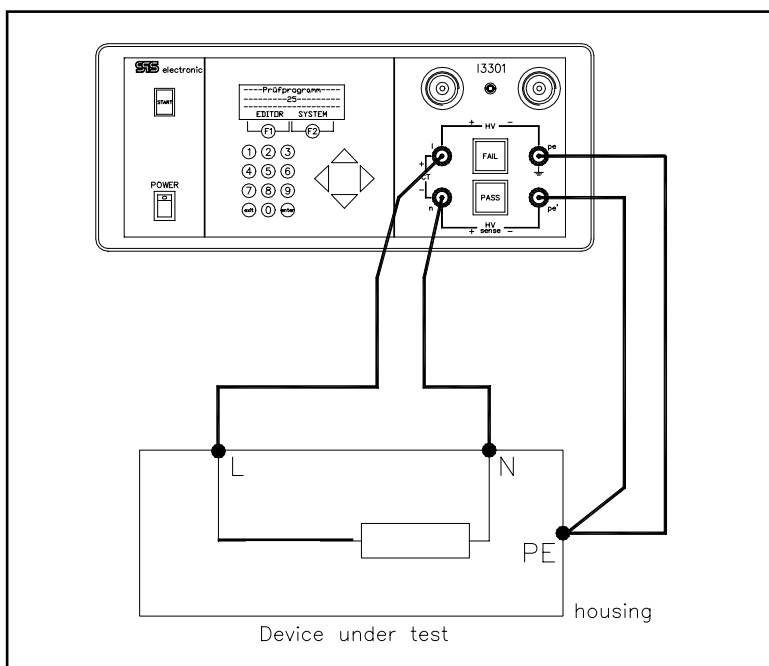

Remark:
HV⁻ is grounded!

3.2 Changing of program settings

3.2.1 General notes to manual programming







To find your way through the program, below symbols will be used:

 function of LCD display

 input

Displays on LCD appear in *typewriter* characters

Moving through the menus

- With the cursor keys () set the arrow cursor in the LC display to the desired menu option.
- With F2 or **enter** the chosen menu option is confirmed.
- To leave the actual screen, press F1 or **exit**. This will bring you back to the previous screen.

For entry of letters, numbers and special characters with number keys (needed when entering name of program)

- with key ① 1 character forward
- with key ④ 1 character backward
- with key ② 5 characters forward
- with key ⑤ 5 characters backward
- with key ③ 10 characters forward
- with key ⑥ 10 characters backward
- With the cursor keys the cursor can be moved to a position in the program name to enter characters.

3.2.2 Programming individual test programs

The insulation test device **I 3304** can store up to 100 different testing programs. Delivered devices contain the default test program on all program numbers. The default test program (called »NONAME«) contains all available tests with their default values.

To arrange an individual test program, proceed the following steps:

1. Set the tester back to basic display:
 - switch the **I 3304** off and on, or press <F1> several times
2. choose the desired number of test program (1-50) :
 - press <F2> (Prgno.)
 - enter the desired number of test program with number or cursor keys
 - acknowledge your selection with <F2>
3. to upset the test parameters:
 - with cursor keys, scroll to the test to be changed
 - please see chapter 3.3, page 27ff. for a detailed description of all test parameters
 - if you wish a test to be skipped, set *TEST TIME* to 0.0

Every change in a test program will be saved immediately when pressing <F2> (<OK>).

In case you made silly changes and wish to reset parameters to former status, simply press <F1> (<CANCEL>)

Basic display will appear after switching on of tester:

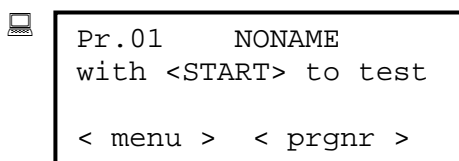

```

Pr.01      NONAME
with <START> to test

< menu >  < prgnr >
    
```

After pressing key F1 (< menu >), menu password has to be entered. (depends on the setting »password« in *system parameter*)

Display of parameter groups:

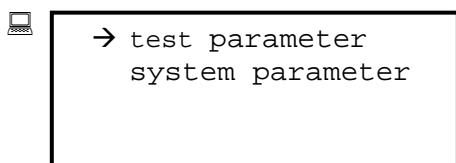

```

→ test parameter
   system parameter
    
```

1. select parameter group:
 - ☞ with cursor keys, set arrow (→) to the desired parameter group
 - ☞ acknowledge selection with F2 (< select >)
2. have parameter of a parameter group displayed or changed:
 - for changing of test parameter pl. see p. 25ff
 - for changing of system parameter pl. see p. 22

3.2.3 Changing of system parameters

After having preselected the parameter group `system parameter`, you can select a function (pl. see p.20). To change it:

1. go to `system parameter` with cursor keys and select with F2 (< select >)
2. changing of presetting:

LANGUAGE

 press F2 (< select >)

 German

 English

 select desired language with cursor keys and acknowledge with F2 (< OK >)
all the displays will be switched automatically to the chosen language

OPERATING MODE

 press F2 (< select >)

 manual

automatic (*remote control via PC to RS 232 interface*)

digital (*program selection via external I/O*)

 preselect operating mode with cursor keys and acknowledge selection with F2 (< OK >)

SYSTEM TIME

 press F2 (< select >)

 08:00

 enter time (hours : minutes) with numeric keys and acknowledge with F2 (< OK >).

SYSTEM DATE

 press F2 (< select >)

 06.10.1998

 enter date (day.month.year) with numeric keys and acknowledge with F2 (<OK>)

BUZZER

 press F2 (< select >)

 loud

soft

off

 select volume with cursor keys and acknowledge selection with F2 (< OK >)

... CHANGING OF SYSTEM PARAMETERS

 PRINT FORMAT ###

☞ press F2 (< select >)

 condensed *(print test protocols with format 40 characters per line)*

page *(print test protocol page by page)*

endless *(print test protocol continuously)*

☞ select printer format with cursor keys and acknowledge with F2 (< OK >)
 (for examples for above formats, pl. see appendix)

 PROTOCOL ###

☞ press F2 (< select >)

 never *(do not print test results)*

pass *(print test results only when test was passed)*

error *(print test results only when test was not passed)*

always *(print results after each test)*

☞ select protocol setting with cursor keys and acknowledge with F2 (< OK >)

 PASSWORD ###

☞ press F2 (< select >)

 proppassword *(access to program selection permitted)*

menupassword *(access to preset programs permitted)*

☞ select password type with cursor keys and acknowledge with F2 (< select >)

 password please:

☞ enter current password with numeric keys

(for devices to be delivered the password is 0000 [deactivated])

 new password?

☞ press F2 (< select >)

☞ enter new password with numeric keys

 store password?

☞ press F2 (< select >)

⇨ the new password is stored and activated (if other than 0000)

 SERIAL NUMBER ###

☞ press F2 (< select >)

 yes *requesting input of a serial number before each test (up to 20 characters from 0 to 9 possible)*

no *no serial number*

 HEADING LINE ###

☞ press F2 (< select >)

☞ enter heading line (up to 40 characters) with cursor keys (pl. see hint at p.20)

☞ acknowledge input with F2 (< OK >)

Serial number and heading line are only required for print-out.



... CHANGING OF SYSTEM PARAMETERS

 MEASUREMENT *(Only if device has 4-wire-technique. This setting affects the HV-Test only!)*

 press F2 (<select>)

 2-wire *(measurement with 2-wire-technique)*

4-wire *(measurement with 4-wire-technique)*

 choose measurement method with cursor keys

 acknowledge input with F2 (< OK >)

 MULTISTART *(See appendix A: Special functions)*

 press F2 (< select >)

 select desired value for multistart (1-4)

 acknowledge input with F2 (< OK >)



3.2.4 Changing of test parameters

After having preselected the parameter group `test parameter`, you can select a test function: (pl. see p. 20)

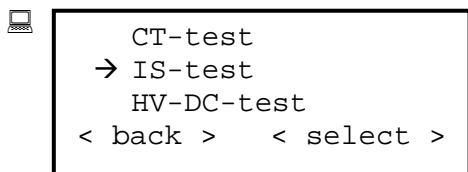

1. select test function :

- ☞ with cursor keys, set arrow (→) to the desired parameter group
- ☞ acknowledge selection with F2 (< select >)

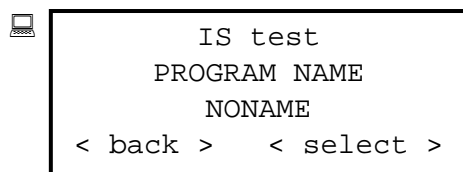

(first test parameter)

2. select test parameter:

- ☞ go to desired test parameter with cursor keys
- ☞ acknowledge selection with F2 (< select>)

For a detailed description of the test parameters, please see paragraph 3.3, page 27ff.

3.3 Executing tests

1. If provided for, switch on external devices (control desk, PC, printer)
2. Switch on power switch (key switch) at tester
 - ⇒ tester initializes itself automatically.
 - after about five seconds basic display will appear

Basic display after switching on of tester:

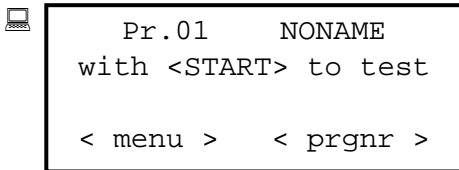

```

Pr.01      NONAME
with <START> to test

< menu >  < prgnr >
  
```

3. Select one of below functions:

- **Executing test with preset program**

(the program number is displayed)

- ☞ press key START in the front panel and release again
 - ⇒ lights *fail* and *pass* light up as long as key is pressed
- ☞ enter serial number if necessary
 - (depending on system parameter `serial number`, pl. see paragraph 3.2.3)
 - ⇒ test is started
- ☞ for individual test steps press key START if necessary

- **Loading of a different program**

- ☞ press F2 to select < prgno >
- ☞ enter program password (if active)
 - ☞ enter desired program number
 - ☞ press F2 (< OK >)
 - ⇒ program is being loaded
- or*
- ☞ change program number step by step with cursor keys
- ☞ press F2 (< OK >)
- ⇒ program is being loaded

- **Changing of program settings**

- ☞ press F1 to select < menu >
- ☞ enter menu password (if active)
- ☞ for changing of preset programs pl. see paragraph 3.3, page 27ff.



3.3.1 Continuity test

For the continuity test 24 V DC are applied between the connections **L** and **N**, the current flowing (up to 999 mA) is being measured.

If there are values of current **between I_{min} and I_{max}** , DUT **passed** the continuity test.
Green light *pass* will light up.

If there are values of current **smaller than I_{min} or larger than I_{max}** , DUT **failed** continuity test, i.e. DUT is not contacted or its insulation is insufficient
Red light *fail* will light up.



The testing voltage of the CT test is not stabilized, and may vary depending on load.



Proceeding

After having chosen the parameter group `test parameter` (see p. 20) you'll have to choose the test funktion `CT test`:

- ☞ with cursor keys, set arrow (→) to `CT test`
- ☞ acknowledge selection with F2 (< select >)



```

CT test
PROGRAM NAME
NONAME
< back >  < select >
    
```

(first test parameter)

Selection of test parameter:

- ☞ go to desired test parameter with cursor keys
- ☞ acknowledge selection with F2 (< select >)

Test parameters of CT test

PROGRAM NAME ###

- ☞ enter program name with numeric keys (pl. see hint on p.20)
- ☞ acknowledge input with F2 (< OK >)

PERFORM

- yes *(execute continuity test between L and N [for 1 sec])*
- no *(no continuity test)*

- ☞ acknowledge selection with F2 (< OK >)

min. current ### mA

- ☞ enter numeric value (000 – 998) with cursor or numeric keys
- ☞ acknowledge input with F2 (< OK >)

max. current ### mA

- ☞ enter numeric value (000 – 999) with cursor or numeric keys
- ☞ acknowledge input with F2 (< OK >)

While $I_{max} \leq 998$ mA, this value must not be exceeded.
When $I_{max} = 999$ mA, the current is no longer watched over. This means, if there is any continuity (no matter if e.g. 5 mA or even 2 A), the test result is GOOD.



3.3.2 Insulation test

For the insulation test the connections (L+N) and PE are bridged and voltage is applied. If DUT is sufficiently insulated, no partial current will flow back via its PE-line.

Therefore resistance between N+L and PE must be as high as possible.

If there are values of resistance **larger than R_{min}** , DUT **passed** insulation test, i.e. DUT is insulated acc. to regulations.

Green light *pass* will light up.

If there are values of resistance **smaller than R_{min}** DUT **failed** insulation test, i.e. its insulation is insufficient.

Red light *fail* will light up.

Proceeding

After having chosen the parameter group test parameter (see p. 20) you'll have to choose the test funktion IS test:

- ☞ with cursor keys, set arrow (→) to IS test
- ☞ acknowledge selection with F2 (< select >)



```

IS test
PROGRAM NAME
NONAME
< back >   < select >

```

(first test parameter)

Selection of test parameter:

- ☞ go to desired test parameter with cursor keys
- ☞ acknowledge selection with F2 (< select >)

Test parameters of IS test:

 PROGRAM NAME ###

- ☞ enter program name with numeric keys (pl. see hint on p.20)
- ☞ acknowledge input with F2 (< OK >)

 TEST TIME ##.# s

- ☞ enter numeric value (00.0 – 60.0) with cursor or numeric keys
- ☞ acknowledge input with F2 (< OK >)

 TEST MODE

test (t)

- ☞ press F2 (<select>)

















 test (t) (test ends after the programmed test time)

static (test ends after failure or user break, e.g. pressing <F1>)

- ☞ choose desired test mode with cursor keys
- ☞ acknowledge selection with F2 (<OK>)



... TEST PARAMETERS IS-TEST

-  START MODE
 immediately
 -  press F2 (<select>)
-  immediately (*start test immediately*)
 start (*start test with start button*)
 start & hold (*test control must be pressed during whole test time*)
 -  select desired test mode with cursor keys
 -  acknowledge selection with F2 (<OK>)
-  NUMBER
 -  enter value (00 to 99) with cursor- or numeric keys
 -  acknowledge input with F2 (<OK>)
-  VOLTAGE
 1500 V
 -  enter desired test voltage with cursor- and/or numeric keys. The test voltage must be between 40 V and 6000 V. The topmost line of the display will show the valid range for R_{min} , which is internally calculated referring to the chosen test voltage.
-  Threshold R_{min}
 02.01 M Ω
 -  enter value with cursor- or numeric keys. The topmost line of the display will show the valid range according to the programmed test voltage.
 In doing so, one can switch between ranges k Ω , M Ω and G Ω with the cursor keys \blacklozenge .
 -  acknowledge input with F2 (<OK>)
-  VOLTAGE RAMP
 05.0 S
 -  enter value with cursor- or numeric keys (00.0 – 60.0 s)
 -  acknowledge input with F2 (<OK>)

Test voltage and measurement range

The insulation test device I 3304 works – depending on the chosen test voltage and R_{min} – in three different measurement ranges, which are automatically switched.

While entering the test voltage or R_{min} , the possible range for R_{min} and R_{max} is displayed at the display's top border

Some typical examples are shown on the next page:



... INSULATION TEST: TEST VOLTAGE AND MEASUREMENT RANGE

The calculation of the measurement range or R_{max} refers to the following formulas :

U_{nom} 40 - 400 V	$500 \mu A < U_{nom} / R_{min} \leq 5 \text{ mA}$: $R_{low} = U_{nom} / 5 \text{ mA}$; $R_{high} = U_{nom} / 100 \mu A$ (1)
	$50 \mu A < U_{nom} / R_{min} \leq 500 \mu A$: $R_{low} = U_{nom} / 500 \mu A$; $R_{high} = U_{nom} / 10 \mu A$ (2)
	$U_{nom} / R_{min} \leq 50 \mu A$: $R_{low} = U_{nom} / 50 \mu A$; $R_{high} = U_{nom} / 2,5 \mu A$ (3)
U_{nom} 400 - 600 V	$U_{nom} / R_{min} \leq 20 \mu A$: $R_{low} = U_{nom} / 20 \mu A$; $R_{high} = U_{nom} / 1 \mu A$ (4)
U_{nom} 600 - 6000 V	$200 \mu A < U_{nom} / R_{min}$: $R_{low} = U_{nom} / 2 \text{ mA}$; $R_{high} = U_{nom} / 40 \mu A$ (5)
	$20 \mu A < U_{nom} / R_{min} \leq 200 \mu A$: $R_{low} = U_{nom} / 200 \mu A$; $R_{high} = U_{nom} / 4 \mu A$ (6)
	$U_{nom} / R_{min} \leq 20 \mu A$: $R_{low} = U_{nom} / 20 \mu A$; $R_{high} = U_{nom} / 1 \mu A$ (7)

U_{nom} = test voltage

R_{min} = required minimum resistance of DUT

R_{low} = minimum resistance which can be measured by the I 3304

R_{high} = maximum resistance which can be measured by the I 3304

Example 1:

A test will be run with a voltage of 500 V. DUT shall have a minimum resistance of 4 M Ω .

Cause of $\frac{U_{nom}}{R_{min}} = \frac{500 \text{ V}}{4 \text{ M}\Omega} = 125 \mu A$ and $50 \mu A < 125 \mu A \leq 500 \mu A$ formulas (2) are valid:

$$R_{low} = \frac{U_{nom}}{500 \mu A} = \frac{500 \text{ V}}{500 \mu A} = 1 \text{ M}\Omega \quad R_{high} = \frac{U_{nom}}{10 \mu A} = \frac{500 \text{ V}}{10 \mu A} = 50 \text{ M}\Omega$$

Example 2:

A test will be run with a voltage of 500 V. DUT shall have a minimum resistance of 12 M Ω .

Cause of $\frac{U_{nom}}{R_{min}} = \frac{500 \text{ V}}{12 \text{ M}\Omega} = 41,7 \mu A$ and $41,7 \mu A \leq 50 \mu A$ formulas (3) are valid:

$$R_{low} = \frac{U_{nom}}{100 \mu A} = \frac{500 \text{ V}}{50 \mu A} = 10 \text{ M}\Omega \quad R_{high} = \frac{U_{nom}}{2,5 \mu A} = \frac{500 \text{ V}}{2,5 \mu A} = 200 \text{ M}\Omega$$

Example 3:

A test will be run with a voltage of 2500 V. DUT shall have a minimum resistance of 12 M Ω .

Cause of $\frac{U_{nom}}{R_{min}} = \frac{2500 \text{ V}}{12 \text{ M}\Omega} = 208 \mu A$ and $200 \mu A < 208 \mu A$ formulas (5) are valid:

$$R_{low} = \frac{U_{nom}}{2 \text{ mA}} = \frac{2500 \text{ V}}{2 \text{ mA}} = 1,25 \text{ M}\Omega \quad R_{high} = \frac{U_{nom}}{40 \mu A} = \frac{2500 \text{ V}}{40 \mu A} = 62,5 \text{ M}\Omega$$

Example 4:

A test will be run with a voltage of 2500 V. DUT shall have a minimum resistance of 500 M Ω .

Cause of $\frac{U_{nom}}{R_{min}} = \frac{2500 \text{ V}}{500 \text{ M}\Omega} = 5 \mu A$ and $5 \mu A \leq 40 \mu A$ formulas (7) are valid:

$$R_{low} = \frac{U_{nom}}{20 \mu A} = \frac{2500 \text{ V}}{20 \mu A} = 125 \text{ M}\Omega \quad R_{high} = \frac{U_{nom}}{1 \mu A} = \frac{2500 \text{ V}}{1 \mu A} = 2,5 \text{ G}\Omega$$

3.3.3 High voltage test DC

For the high voltage test, a voltage is applied to the connections (L+N) and PE. If DUT is sufficiently insulated, no partial current will flow back via its PE-line.
 Therefore resistance between N+L and PE must be as high as possible.
 If there are values of current **smaller than I_{max}** , DUT **passed** the high voltage test.
 Green light *pass* will light up.
 If there are values of current **larger than I_{max}** , DUT **failed** high voltage test, i.e. its insulation is insufficient
 Red light *fail* will light up.

Proceeding

After having chosen the parameter group `test parameter` (see p. 20) you'll have to choose the test funktion `HV-DC test`:

- ☞ with cursor keys, set arrow (→) to `HV-DC test`
- ☞ acknowledge selection with F2 (< select >)

```

    HV-DC test
    PROGRAM NAME
    NONAME
    < back >   < select >
    
```

(first test parameter)

Selection of test parameter:

- ☞ go to desired test parameter with cursor keys
- ☞ acknowledge selection with F2 (< select >)

Test parameters of HV-DC test

- ☞ PROGRAM NAME ###
 - ☞ enter program name with numeric keys (pl. see hint on p.20)
 - ☞ acknowledge input with F2 (< OK >)
- ☞ TEST TIME ##.# s
 - ☞ enter numeric value (00.0 – 99.9) with cursor or numeric keys
 - ☞ acknowledge input with F2 (< OK >)
- ☞ TEST MODE
 - test (t)
 - ☞ press F2 (<select>)
- ☞ test (t)
 - static
 - ☞ select desired test mode with cursor keys
 - ☞ acknowledge selection with F2 (<OK>)



... TEST PARAMETER HV-DC TEST

- ☞ STARTMODUS
IMMEDIATELY
 - ☞ press F2 (<select>)
 - ☞ IMMEDIATELY *(test starts immediately)*
 - ☞ START *(start test with start key)*
 - ☞ START&HOLD *(test control must be pressed during whole test time)*
 - ☞ select desired test mode with cursor keys
 - ☞ acknowledge selection with F2 (<OK>)

- ☞ NUMBER
01
 - ☞ enter value (00-99) with cursor- or numeric keys
 - ☞ acknowledge input with F2 (<OK>)

- ☞ VOLTAGE
0060 V
 - ☞ enter the desired test voltage with cursor- or numeric keys. The test voltage must be between 40 V and 6000 V. The topmost line of the display will show the required range for I_{max} , which is internally calculated from the chosen test voltage.

- ☞ MAX. CURRENT
1.99 mA
 - ☞ enter numeric value (from 0.0 to 4.0) with cursor or numeric keys
 - ☞ acknowledge input with F2 (< OK >)

- ☞ VOLTAGE RAMP
05.0 S
 - ☞ enter value (00.0-60.0) with cursor- or numeric keys
 - ☞ acknowledge input with F2 (<OK>)

3.4 Remote control via RS 232

1. From system parameter (see 3.2.3, S.22) select OPERATING MODE automatic

A message appears on display:

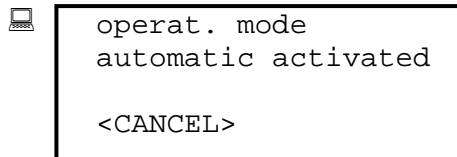

```

operat. mode
automatic activated

<CANCEL>
    
```

- ⇒ the device is now in remote mode and remains in this mode also after powering the device off and on

To leave this mode:

- ☞ press F1 (<CANCEL>) for about 3 sec and
- ☞ turn power switch off and on
- ⇒ tester initializes itself.

2. The tester can be controlled by commands described in the following chapter.
3. The evaluation of measuring results (pass, fail) is up to the user (PC).

Below please find description and syntax of commands for data exchange between tester *I 3304* and PC. Data exchange is made via serial interface.

3.4.1 Syntax

- command format
[command]<LF> max. length 40 characters
- answer format
[answer]<LF>
- commands
 - *[global command] permanently available command
 - [local command] command depending on structure which can only be executed under certain conditions
- global and local commands

[execute command]	controls tester directly
[configuration command]<SP>[parameter]	sets device parameter
[data request command]?	expects a value

3.4.2 Global commands

- *IDN? verifies device identification
example for answer: I3304D, Ver. 1.07, 07.07.2001<LF>
- *VER? verifies version of device control
example for answer: 600<LF>
- *MOD? verifies current device mode
example for answer: 5<LF>
- *STA? reads status register
example for answer: 3<LF>
- *LLO<status> Enables or disables the possibility of test abort by the button F1 on the device keyboard, according to the value of *status*:
0 = enable abort
1 = disable abort (active until power off)
- *LLO? queries if status is locked or unlocked
example for answer: 0<LF> unlocked
1<LF> locked
- *INP<digital input>? Reads the status of digital input.
Possible answers are: 0 = off, 1 = on.
Digital input format ist NN (always 2 digits).
example for answer: 0<LF>
Standard digital inputs:
INT_START (HV-pistol) 13
EXT_START (test hood) 08
EXT_ACK 06
- *ERR? reads first (oldest) stored error from error queue and deletes it there
error-ID and description are divided by » , «
error queue is a first-in, first-out (FIFO) and can store maximally 10 errors
if error buffer is full, then error »200,Queue Overflow« will be stored on the last position
example for error: 0, No error<LF>
- *CEQ clears all errors from error queue.
- *CLS clears status register and error queue as well as input and output buffer for serial communication.
Breaks the testing (if running) and puts device in idle state.
The parameters set by commands CONF remain but the type of latest test and ist result are cleared.
- *RST returns the device to the power-on startup conditions.
It is the same as *CLS command but all test parameters are set on their default values.

3.4.3 Local commands

● **CONF group**

Continuity test

There is not any parameter to set.

Insulation test

- CONF:IS:TIME<test time> sets test time: range 00.0 – 99.9; default 05.0 [s]
- CONF:IS:TIME? queries currently set test time
- CONF:IS:RAMP<ramp time> sets time for starting ramp:
range 00.0 – 60.0; default 00.0 [s]
- CONF:IS:TIME? queries currently set ramp time
- CONF:IS:VOLT<Unom> sets test voltage:
range 0040 – 6000; default 0500 [V]
- CONF:IS:VOLT? queries currently set test voltage
- CONF:IS:RMIN<Rmin> sets threshold for R_{min}

The range of R_{min} depends on the test voltage:

U _{nom} = 0040	→	range R_{min} : 8.00 k Ω - 15.99 M Ω
...		... (linear function)
0400	→	range R_{min} : 80.00 k Ω - 0.15 G Ω
U _{nom} = 0401	→	range R_{min} : 80.20 k Ω - 0.39 G Ω
...		... (linear function)
0600	→	range R_{min} : 0.12 M Ω - 0.59 G Ω
U _{nom} = 0601	→	range R_{min} : 0.30 M Ω - 0.59 G Ω
...		... (linear function)
6000	→	range R_{min} : 3.00 M Ω - 5.99 G Ω

Parameter's format is N.NNNE+NN, value is in [Ω],
Default is 10 M Ω .

Example: CONF:IS:RMIN 1.000E+07 sets R_{min} =10 M Ω

- CONF:IS:RMIN? queries currently set value for R_{min}
- CONF:IS:TMODE:TEST|STAT sets test mode: test time (TEST) or endless (STAT)
- CONF:IS:TMODE? queries currently set test mode
- CONF:IS:START:OFF|MAN|HOLD sets starting type:
 - OFF = start immediately, default
 - MAN = manual (start button)
 - HOLD = test control must be pressed during all test
- CONF:IS:START? queries actual start type
- CONF:IS:DEF sets all parameters for insulation test on their default values: 5 s, 5M, SOCK



High voltage test DC

CONF:HS:TIME<test time>	sets test time: range 00.0 – 99.9; default 05.0 [s]
CONF:HS:TIME?	queries currently set test time
CONF:HS:RAMP<ramp time>	Sets the time of starting ramp range 00.0 - 60.0, default 00.0 [s].
CONF:HS:RAMP?	queries the actual value of ramp time.
CONF:HS:VOLT<nominal voltage>	Sets the nominal voltage of measurement. range 0040 - 6000, default 1500 [V]
CONF:HS:VOLT?	queries the actual value of nominal voltage.
CONF:HS:IMAX<maximum current>	Sets threshold for maximal current this depends on the test voltage: $U_{nom} = 0040 - 0600 \rightarrow \text{range } I_{max} = 0.0 - 4.99 \text{ [mA]}$ $U_{nom} = 0601 - 6000 \rightarrow \text{range } I_{max} = 0.0 - 1.99 \text{ [mA]}$ Parameter format is N.NNNE+NN, value is in [A] Threshold is 1.0 mA <i>Example:</i> CONF:HS:IMAX 1.000E-03 sets $I_{max} = 1 \text{ mA}$
CONF:HS:IMAX?	queries the actual value of maximal current.
CONF:HS:TMODE:TEST STAT	Sets the testing mode: with test time (TEST) or endless (STAT)
CONF:HS:TMODE?	queries the actual value of testing mode.
CONF:HS:MEAS:SOUR SENS	Sets the measuring mode: SOUR = 2-wire-method (default) SENS = 4-wire-method
CONF:HS:MEAS?	queries the actual value of measuring mode.
CONF:HS:START:OFF MAN HOLD	Sets the start mode: OFF - start test immediately (default) MAN - start test manually with start button HOLD - test control must be pressed during all test
CONF:HS:START?	queries the actual value of start mode.
CONF:HD:DEF	sets all parameters for DC-high voltage test to their default values

- **MEAS group**

MEAS:CT	starts continuity test
MEAS:IT	starts insulation test
MEAS:HS	starts high voltage test DC
MEAS?	queries currently set test method

- **READ group**

Continuity test

READ:CT:CURR?	expects value for current, result is in [A] ^{EXPONENT} <i>Answer example:</i> 1.000E-01<LF>
---------------	---

Insulation test

READ:IS:CURR?	expects value for current, result in [A] ^{EXPONENT} <i>Answer example:</i> 1.250E-03<LF>
---------------	--

READ:IS:VOLT?	expects value for voltage, result [V] <i>Answer example:</i> 0650<LF>
---------------	--

READ:IS:RES?	expects resistance value, result in [Ω] ^{EXPONENT} <i>Answer example:</i> 2.320E+06<LF>
--------------	--

High voltage test DC

READ:HS:VOLT?	expects value for voltage, result in [V] <i>Answer example:</i> 2500<LF>
---------------	---

READ:HS:CURR?	expects value for current, result in [A] ^{EXPONENT} <i>Answer example:</i> 1.000E-01<LF>
---------------	--

- **SYST group**

SYST:TEST:ON OFF	Switches output EXT_TEST
SYST:HALT	interrupts testing
SYST:PASS:ON OFF	green signal light is switched on or off
SYST:FAIL:ON OFF	red signal light is switched on or off
SYST:BEEP:SOFT LOUD	buzzer is switched on to either soft or loud volume for 100 ms

3.4.4 Status and error parameters

- **Command version** (controlling variant)

Device constant including which commands are supported by tester.

The one hundred (in future also the one thousand) digit positions characterizes the basic model, the other two positions are planned for variants. The value list will be updated when a new variant is being executed.

This value can be read by the command *STA?.

<i>C. version</i>	<i>Device name</i>	<i>Description</i>
440	I 3304D	basic model with 2-wire-technique
441	I 3304S / I 3304L	Same as I 3304D, but with 4-wire-technique

- **Device mode** (device type)

Characterizes the current operating mode of tester. The value is in range 0-255 (unsigned shortint type in C-language)

This value can be read by the command *STA?.

Bit position	B7	B6	B5	B4	B3	B2	B1	B0
Meaning	<u>operating mode</u>			<u>data exchange</u>		<u>remote status</u>		
<u>Operating mode</u>	manual			automatic		digital		
Bits B7 – B6 – B5	000 (0)			001 (32)		010 (64)		
<u>Data exchange</u>	RS-232			IEEE-488				
Bits B4 – B3	00 (0)			01 (8)				
<u>remote status</u>	testing			program exchange		result exchange		
Bits B2 – B1 – B0	000 (0)			001 (1)		010 (2)		

Data exchange and remote status are only relevant in operating mode »automatic«



- **Status register**

Characterizes the current activity when the device performs a testing.

This value can be read by the command *STA?.

Bit position	B7	B6	B5	B4	B3	B2	B1	B0
Meaning	<u>activity</u>				<u>test end</u>			

Status	hex	bin	dec
<u>Activity</u>			
idle state	\$00	0000 0000	0
test starting	\$10	0001 0000	16
test preparing	\$20	0010 0000	32
rampe up *	\$30	0011 0000	48
measuring	\$60	0110 0000	96
rampe down *	\$50	0101 0000	80
test ending	\$40	0100 0000	64
test finished	\$80	1000 0000	128
<u>Test end</u>			
STOP button	\$81	1000 0001	129
HA-test – high current	\$82	1000 0010	130
PW-test – start timeout	\$83	1000 0011	131
PW-test – disconnected	\$84	1000 0100	132
2-hand-control released	\$85	1000 0101	133
after SYST:HALT	\$8F	1000 1111	143
<i>* only when supported by device variant</i>			

... STATUS AND ERROR PARAMETERS**Error messages**

They describe errors in command syntax or of their wrong use as well as device depending errors. The value is in range 0-255 (unsigned shortint type in C-language).

Number	Description
200	Queue overflow
0	No error
1	Invalid start character
2	Invalid end character
3	Invalid command
4	Invalid MEAS parameter
5	Invalid CONF parameter
6	Invalid SYST parameter
7	Invalid READ parameter
8	
9	Unable to start measurement

3.5 Error display

3.5.1 Error display

Most errors are displayed on the LCD (see below).
Furthermore the red light *fail* signals the error if

- operator aborted or if
- there was an error during the test

3.5.2 Error messages on LC display

Error messages are not displayed in plain text on the LCD.
Exceptions:

- ## NN-test FAIL
if DUT failed current (##) test during IS or HV test (NN)
 - ☞ repeat with F2 (< REPEAT >) or key START
 - ☞ accept with F1 (< END >) and continue

You will find error/failure causes in the printer protocol (page or endless)
(pl. see appendix, page 49).

3.6 Maintenance and function check

3.6.1 Maintenance

The insulation test device I 3304 needs no serving.



Pull plug before opening housing!
There are four fuses in the device which, if necessary, have to be replaced.

SPS electronic GmbH recommends to return series 3300 devices **for an annual check** to guarantee the accuracy of calibration/measured values.

Should defects be detected when checking those testers, then the device in question has to be recalibrated by *SPS electronic GmbH*.

3.6.2 Function check

Dummy test

To check functions of the testers or if you suspect some irregular function you should execute a dummy test regularly:

To do so execute with the tester protective wire, insulation or high voltage tests respectively at one or several DUTs – DUTs which will positively not pass these tests or for which different measurement results have already been established.

Please compare the results of both measurements afterwards.

Should the results be about the same, then the tester functions perfectly, without errors.

Appendix

A Special functions

A-1 Program 0 (only in operating mode manual)



```

please go with key
START to IS-TEST

<END>    <CONTINUE>
    
```

If the number of tests to be executed is unknown, then the test can, in the current test mode, be repeated with program 0 until you

- end with option <END>
- or*
- select another test mode with option <CONTINUE>.

A-2 Digital program selection

In system parameter the operating mode *digitally* can be selected (pl. see 3.2.3). In this operating mode the test program is preselected via the digital interface *ext. IO* (Dsub25) at the back by coding the inputs 0 bis 3 binarily:

Pin-no. at Dsub25	14	13	12	11	<i>(pl. see p. 45)</i>
associated input	4	3	2	1	

	coding				corresponding to test program no.
<i>1 means: there is voltage of 24 V*</i> <i>0 means: there is no voltage 24 V*</i>	0	0	0	0	0
	0	0	0	1	1
	0	0	1	0	2
	0	0	1	1	3
	0	1	0	0	4
	⋮				⋮
	1	1	1	1	15

*24 V : unfiltered voltage (please see PIN configuration ext. IO-interface)

A-3 Multistart - Tests

Often it can be useful to process several test programs one after another automatically. Conceivable uses would be e.g. to let a DUT be tested with different voltage levels or to test different wirings over a test hood.

For this purpose the function multi-start was integrated in the insulation test device *I 3304*. To use this function, go to the parameter `Multistart` within the parameter group `System Parameter` and select the desired value.

Multistart works as follows:

- After switching on the device, at first the last run test program will be performed.
- After finishing this program, the next program in the device's memory (program number + 1) will be run ...
- etc. ...

This means, if in the last session the program no. n was active, then

- Multistart 1 will run only program number n
- Multistart 4 will run the programs n to $n+3$ one after another
- Multistart 2 and 3 accordingly



According to the chosen multistart program the corresponding output of the external I/O-interface will be set automatically.

To use the »Multistart« functionality, the following preconditions must be fulfilled:

1. System parameter **operating mode** = **manual** (not automatic, not digital)
2. »n« must be ≥ 1 , i.e. the last used program must not have been »program 0« !

B Interface Configuration

B-1 PIN configuration for external IO-interface

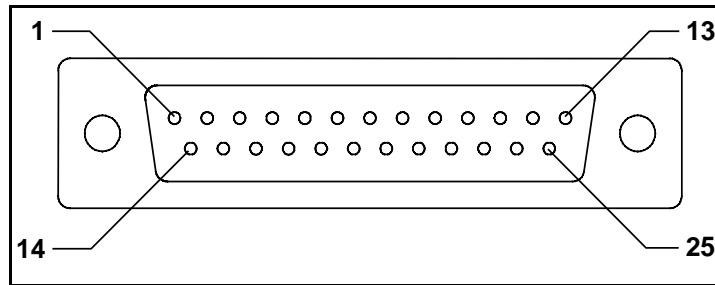

plug ext. I/O (Dsub25)

<i>PIN</i>	<i>description</i>	<i>configuration</i>
1	output 1-	EXT_PASS
2	output 2-	EXT_ERROR
3	output 3-	EXT_BUZZER
4	output 4-	EXT_TEST (active during complete test)
5	output 5-	Multistart 1
6	output 6-	Multistart 2
7	output 7-	Multistart 3
8	output 8-	Multistart 4
9	–	not used
10	–	not used
11	input 1	4 bit-program selection
12	input 2	4 bit-program selection
13	input 3	4 bit-program selection
14	input 4	4 bit-program selection
15	input 5	not used
16	input 6	EXT_ACK
17	input 7	not used
18	input 8	EXT_START
19	–	not used
20	+24 V DC	ext. voltage against mass
21	+24 V DC	ext. voltage against mass
22	–	not used
23	–	not used
24	GNS	mass
25	GNS	mass



Description of most important signals of I/O interface:

Inputs:

- 1 EXT_ACK (input 6)
 - interrupts running tests
 - accepts a faulty measurement

- 2 EXT_START (input 8)
 - starts the test
 - repeats a faulty measurement

Outputs:

- 1 EXT_PASS (output 1)
 - setting same as *pass*-light

- 2 EXT_ERROR (output 2)
 - setting same as *fail*-light

- 3 EXT_BUZZER (output 3)
 - setting same as built-in buffer

- 4 EXT_TEST
 - to be set after first start signal and stays active during entire test

- 5-8 Multistart 1 – Multistart 4
 - for automatic run of multiple test programs

B-2 PIN configuration for serial printers and remote interface COM1

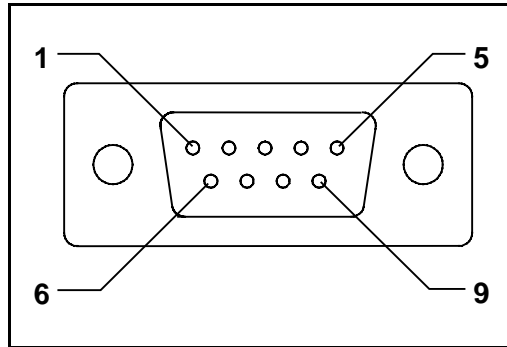

plug RS232 (Dsub9)

<i>PIN</i>	<i>Bezeichnung</i>	<i>Belegung</i>
1	-	not used
2	RxD	receive data
3	TxD	transmit data
4	-	not used
5	mass	reference potential of serial interface
6	-	not used
7	-	not used
8	-	not used
9	-	not used

Interface setting: 9600 baud, 8 data, 1 stopbit, no parity

C Information on programming and program run

C-1 Order of tests in manual or digital mode:

- CT - test
- IS - test
- HV-DC - test

C-2 Miscellaneous

- Protocol print-outs and issuing of audible signals take time after each test step. If protocols and audible signals are not needed, please adjust system parameters:

```
PROTOCOL → never
BUZZER   → off
```
- For digital control a bad result can also be accepted with EXT_ACK. With new start signal the last step is repeated.
- The lights *pass* and *fail* appear after each test step and display always the partial results. The lights go out if a new test step is performed.

D Protocolling of test results

Only in output formats `page` and `endless` will the cause of error be printed in the protocol. The meanings are:



for all types of test	
U.BREAK	test was aborted by operator

for CT-test	
<Imin	falling below min. value for current
>Imax	max. value for current exceeded

for IS-test	
<Rmin	resistance smaller than R_{min}
<Unom	falling below nominal value for test voltage
Usense	voltage measuring faulty
>Imax	max. measuring range of current exceeded

for HV-DC test	
>Imax	max. value for current exceeded
<Usoll	falling below nominal value for test voltage
Usense	voltage measuring faulty

Example for protocol format »page«

```

SPS electronic GmbH
SN: 123
program : 00      NONAME          date : 01.04.1998
-----
* IS-test parameters * t= 05.0 s U= 500 VDC Rmin= 01.00 MOhm
  time |          | resist. | error | result
-----
01: 12:32 |          | 00.2 MOhm | <Rmin | FAIL
02: 12:32 |          | 07.6 MOhm | ----  | PASS
* HVDC-testparameters* t= 05.0 s U= 1500 VDC Imax= 1.0 mA
  time | current | voltage | error | result
-----
01: 12:33 | 0.12 mA | 1.49 kV | ----  | PASS
02: 12:33 | 0.00 mA | 1.49 kV | ----  | PASS
-----
                                total:          FAIL

```

Example for protocol format »condensed«

```

SPS electronic GmbH
Programm :01      END-Test          01.04.1998
-----
* IS-test parameters t= 05.0 s
U= 500 VDC Rmin= 05.00 MOhm
  time |          | resist. | result
-----
St: 12:04 |          | 50.0 MOhm | PASS
01: 12:04 |          | 07.6 Mohm | PASS
* HVDC-test parameters * t= 05.0 s
U= 1500 VDC Imax= 1.0 mA
  time | current | voltage | result
-----
St: 12:05 | 0.01 mA | 1.49 kV | PASS
01: 12:05 | 4.09 mA | 0.08 kV | FAIL
01: 12:06 | 0.15 mA | 1.49 kV | PASS
-----
12:06          total :          PASS

```

E Terms of warranty

1. Warranty period

The warranty period is 12 months after delivery.

2. Conditions for a guarantee claim

- The insulation test device I 3304 must have been put into operation by qualified personnel at the customer's.
- Inspections must be carried out regularly (once a year) and thoroughly (by SPS electronic GmbH).
- Defective or worn parts have to be replaced immediately. The operation of such parts is forbidden for safety reasons.
- Defective parts, subject to guarantee claims, have to be sent to SPS electronic GmbH for inspection.
- Defects occurred must be reported to SPS electronic GmbH immediately.

3. Beginning of guarantee period

Guarantee starts with the date of delivery note.

4. Guarantee

SPS electronic GmbH guarantees a good function of the high voltage test device, a conscientious and professional design and manufacture as well as the use of high-quality material.

All parts are being replaced free of charge if parts became defective or useless during the guarantee period due to the use of inadequate material, manufacturing faults or an imperfect engineering.

5. Excluded from guarantee

- Damages due to outside influences, above all because of handling malpractices or of local conditions.
- Damages at devices from which the serial number has been removed, destroyed or falsified.
- Wear parts, such as fuses, signal bulbs, etc.