

Operating Manual

for protective wire and insulation tester
PI 6001D (10 A) and PI 6011D (25 A)

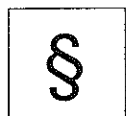

Liability Chapter 1

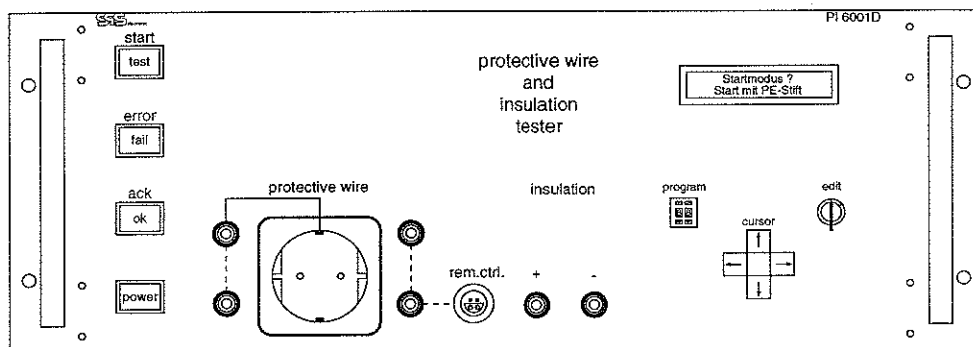

For your safety Chapter 2

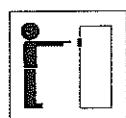

Operation Chapter 3

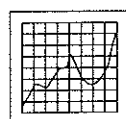

Technical data Chapter 4



Annex Chapter 5



Personnel in charge of and responsible for these tests have to read and must have comprehended the operating instructions, especially the chapter under the heading "For your Safety"!

Please enter below

Serial Number

of your tester
for possible guarantee claims or further inquiries

--	--	--	--	--	--	--	--

There is no guarantee on devices without the original serial number!

Please find serial number here

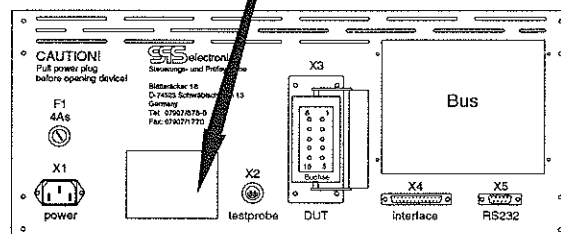

Edition 11/1995

This operating manual must be treated confidentially.

Only authorized personnel are entitled to use same.

A third party's access to same will entail liability for damages.

All rights, including translations, are reserved. No part of this operating manual can be reproduced, or by means of electronic systems be processed, duplicated or circulated without written consent by SPS electronic GmbH.



You are liable in case of negligent operation!

- The test devices are constructed and tested according to the latest technical standards and are, therefore, highly reliable. Yet it can be dangerous if the devices are not being operated properly.

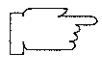

Therefore, please take your time reading this operating manual!

- Liability for the correct operation of the test devices will be transferred in any case to the owner or operator should the device be serviced or repaired inexpertly by personnel not authorized to do so by SPS electronic GmbH or if the device is being operated contrary to its actual purpose (pl. see chapter "Operating Specifications", page 2.3).
- The operator is obliged to use the test device only if it is in perfect condition.
- SPS electronic GmbH is liable to the extent of the guarantee obligations quoted on the confirmation of order, all further claims are excluded.
- In view of the continuous development and improvement of our products we reserve the right to technical changes at all times. Any such changes, errors and/or misprints do not entitle to claims for damages.
- Original SPS electronic GmbH parts and accessories are to be used exclusively.
- SPS electronic GmbH cannot be held liable for damages caused by neglecting the instructions of this operating manual. Guarantee and liability terms of the sales and delivery conditions of SPS electronic GmbH remain in force, i.e. are not affected or changed by the above given information.

SPS electronic GmbH
Blätteräcker 18
D - 74523 Schwäbisch Hall - Sulzdorf

Telephone: (7907) 878-0
Service: (7907) 878-29
Telefax: (7907) 1770

Contents - Chapter 2

Operating safety symbols 2.1

Safety instructions and regulations

Executing tests 2.2

Qualification in personnel 2.2

Organizational requirements 2.2

Operating specifications 2.3

Safety devices 2.3

Operating Safety Symbols

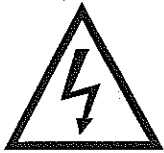

This symbol warns of dangerous electric voltage with danger to life and body of persons.

Please observe these instructions and be especially careful in such cases.

In addition to these operating instructions all the generally accepted instructions on safety and accident prevention must be adhered to.



This symbol warns of danger to life and body of persons.

Please observe these instructions and be especially careful in these cases, too.

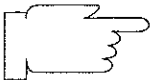

This symbol will give you further important information.

Safety Instructions



Caution - danger of life!

- Pull power plug before opening device.
- Never repair or bridge fuses or other component parts necessary for safety.

■ The testing

Tests can only be started after **all** safety requirements have been fulfilled and same have been checked by the operator in charge of the test.

■ Qualification in personnel

Only qualified and in electronics trained personnel who have the responsibility and dependability to recognize possible dangers are able and to be entrusted with the tests. They have to know the generally approved accident prevention regulations and must also know the generally approved technical regulations (please find a summary of the important regulations and standards in the annex).

Please observe safety regulations (VDE) if using with high voltage!

■ Organizational requirements

A test station, equipped with tester PI 6001D/PI 6011D, may only be operated if a supervising electrician is present.

All defects or damages on the device, on technical equipment and on test installations have to be reported immediately to the supervisor in charge. The test operation has to be stopped until defects and damages have been repaired or removed.

This operating manual has to be kept close to the device so that it is within easy reach of the operator at **any time**.

Organizational requirements

■ Operating Specifications

Application possibilities:

The tester PI 6001D/PI 6011D has been designed for use in modern production areas.

The tester can be used with or without printer as an individual test station (stand-alone). All the tests necessary for individual part inspection can be executed and can be evaluated by means of programmable threshold parameters.

Further application possibilities:

- Fully automatic operation in automatic test systems



The protective wire and insulation tester PI 6001D/PI 6011D must be operated in accordance with this operating manual. Any other use means a violation of the regulations. The manufacturer cannot be made liable for any defects or damages resulting thereof; such a risk is carried exclusively by the operator or user.

Permissible only after having checked with SPS electronic GmbH:

- Electric connections to equipment not mentioned in this operating manual.

Safety devices

- Potential free voltages
- Safety current limitation when testing insulation
- Protective low voltage in case of protective wire test
- Transformer and instrument transformer doubly insulated
- Integrated acoustic warning buzzer

Contents - Chapter 3

Prior to operation 3.1

Description of test possibilities 3.1

Operating controls

Front 3.3

Reverse 3.4

Accessories 3.5

Start of operation

Connection of device 3.6

Operation and function of parameter input unit 3.7

Entry of test program 3.9

Test program -00- 3.9.1

Testing 3.10

Connection of DUT 3.11

Prior to Operation

**Remember!**

You are responsible for safety in the operating range of the test device. Therefore, please pay close attention to chapter 2 "For your Safety" and inform all other operators working in this area respectively.

Basic setting of tester

Depending on the application and purpose of use, the test device can be operated with various basic settings. It is e.g. possible to change the national language on the visual display.

Please look in the annex for how and which basic settings can be altered.

Individual test possibilities

1.1 Protective wire test (resistance measurement according EN 60335/VDE 0700)

The protective wire test measures the resistance of the protective wire between the power supply lines and the housing. The measuring is executed in four-wire measuring technique. The test current at 0.1 Ohm is approx. 10 AAC (for PI 6001D) and 25 AAC (for PI 6011D).

A maximum of 99 protective wire tests per test program are possible. The measurements can be started automatically by means of the protective wire probe when contacting the DUT. Further manual starts are possible by means of keys and limit switches.

1.2 Protective wire test (voltage drop measurement according EN 60204/VDE 0113)

The protective wire test according EN 60204/VDE 0113 is performed by selecting the function voltage drop measurement in the basic settings. Threshold specification for each test step is performed by selecting the corresponding wire cross section via display of the PI 6001D/PI 6011D. The specification of the wire cross section is possible via remote control with the hand key (test program -00-).

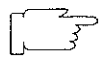
**Please remember when using the autostart**

In order to be able to test efficiently, the device is equipped with an automatic test start for the protective wire test. For a start signal the following conditions have to be met:

- programmed autostart mode
- electric connection between test probe and DUT
- protective wire resistance lower than 5 Ohm
- protective wire main connection of DUT connected to tester

If there is no start signal, then one of the above mentioned conditions has not been met and you are able to generate a manual start on the protective wire probe or on the device.

2. Insulating test

The insulating test measures the resistance between two connecting lines. A test voltage of 500 VDC or 1000 VDC can be programmed for this insulating test. The measuring ranges are 5 MOhm and 50 MOhm.

The device selects the measuring range in relation to the threshold (threshold < 5 MOhm = small measuring range, threshold > 5 MOhm = wide measuring range).

Connection of test voltage at test device possible with:

- built-in standard socket (l+n/pe)
- lab sockets at the front panel
- plug connection DUT at the back
- protective wire test probe

Operating Controls - Front PI 6001D and PI 6011D

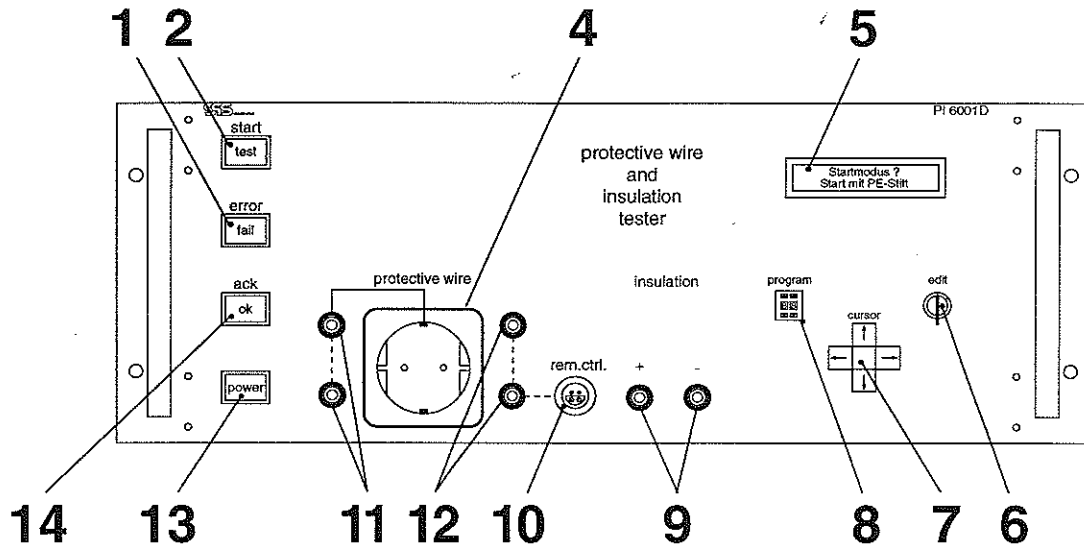

Pos.	Description	Function
1	luminous key "fail" (error)	1. to interrupt test 2. lights if DUT is not within selected test tolerances
2	luminous key "test" (start)	1. to start test run 2. lights during test run 3. to repeat last faulty test step
4	power socket	to connect DUT via power plug
5	visual display	display of adjustable test parameters, etc.
6	key switch "edit"	1. access into editing mode 2. protection against incompetent operation
7	key panel "cursor"	1. to "page through" visual display 2. to acknowledge programmed values
8	BCD switch "program"	to select required test program
9	safety laboratory sockets + / - "insulation"	manual connection for insulation measurement
10	test probe connection socket "rem.ctrl"	to connect test probe PE 13-i or PE 15-i
11	safety laboratory sockets "left" "protective wire" (2 outlets)	manual connection for protective wire test corresponds to the PE contact of the socket. Black Socket = current lead, yellow socket = sensing lead
12	Safety laboratory sockets "right" "protective wire" (2 outlets)	manual connection for the PE-pin. Black socket = current lead, yellow socket = sensing lead
13	luminous key "power"	to turn on device
14	luminous key "ok" (ack)	1. lights if DUT is within selected test tolerances 2. to acknowledge errors on DUT (test is continued with next test step)

Operating Controls - Reverse

PI 6001D and PI 6011D

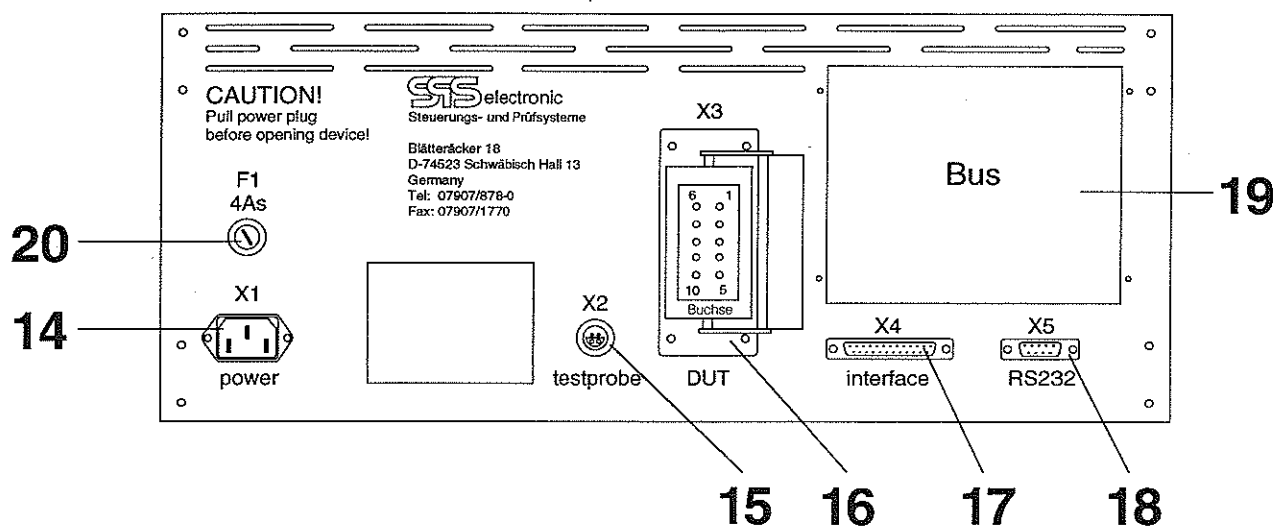

Pos.	Description	Function
14	device plug	IEC 320 connector
15	test probe socket "testprobe"	to connect test probe PE 13-i or PE 15-i
16	DUT socket	to connect DUT
17	Interface socket	to connect hand key
18	RS 232 socket	to connect printer, interface or PC
19	cover for plug-in card slots	After removal of cover access to available plug-in cards will be possible without having to open housing.
20	fuse holder	to protect the test device

Operating Controls - Accessories

Protective wire test probe (21)

Type: PE 13-i or PE 15-i

Connection: **plug-in back panel:**
test probe socket
"testprobe" (15)
front panel:
test probe socket
"rem.ctr" (10)

Function: to contact different test points on housing of DUT. To perform protective wire tests and insulation measurements.

For pin configuration please see page 4.2

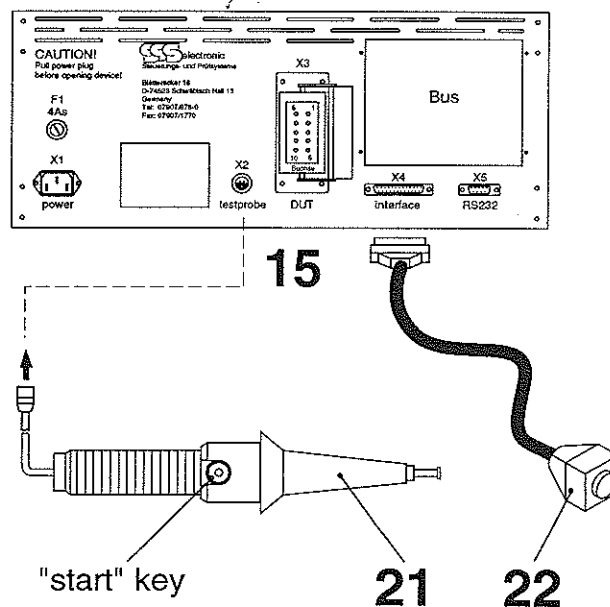

 Test probe PE 13-i without start key.

Hand key (22)

Type: HT 03

Connection: **plug-in back panel:**
"interface" (17)

Function: to select protective wire cross sections for PE-test accord. EN 60204 (only program -00-).

For pin configuration please see page 4.2

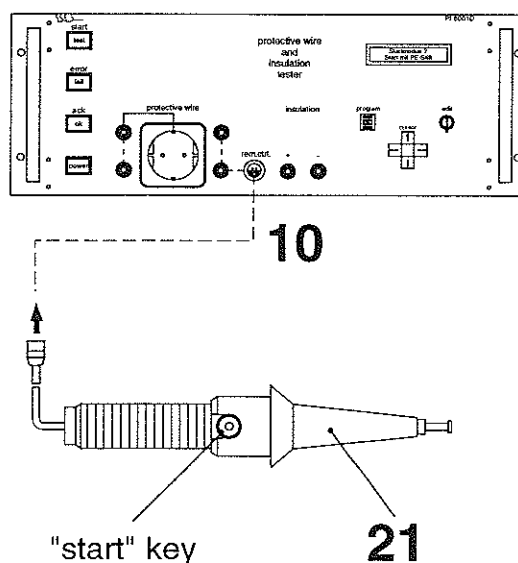

**Remember!**

You are responsible for safety in the working area of the test device. Therefore, please pay close attention to chapter 2 "For your Safety" and inform all other operators working in this area respectively.

To Connect Device



Please be cautious when operating with electric current – there always exists danger of life!

Power supply - via power plug

The tester has to be operated with a voltage of 230 V / 50 Hz.



Different voltages on request.

Plug power line:

- into IEC 320 connector (14) (on the plug-in back panel) and into
- power socket with 230 V / 50 Hz.

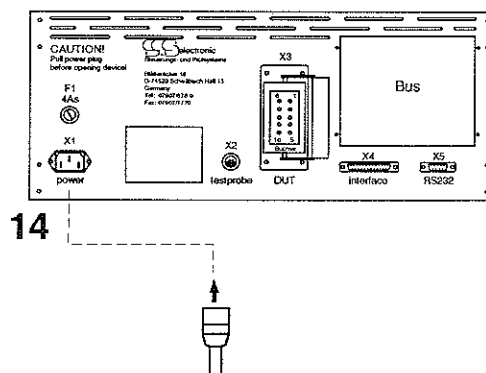

Operation and Function of Parameter Input Unit

Before starting a test all the necessary test parameters (e.g. value of voltage, times.....) for each individual application must be stored in a test program.

These test parameters stored in the test program will then be tested during the test run on the DUT.

 The tests which can be made with the tester are listed in the annex.

A maximum of 50 test programs can be stored. To select the required test program please press BCD switch (8).

Test program parts are available corresponding to the respective test possibilities (please see annex). These test program parts are selected via the key panel "cursor" (7) and are shown on the visual display (5).

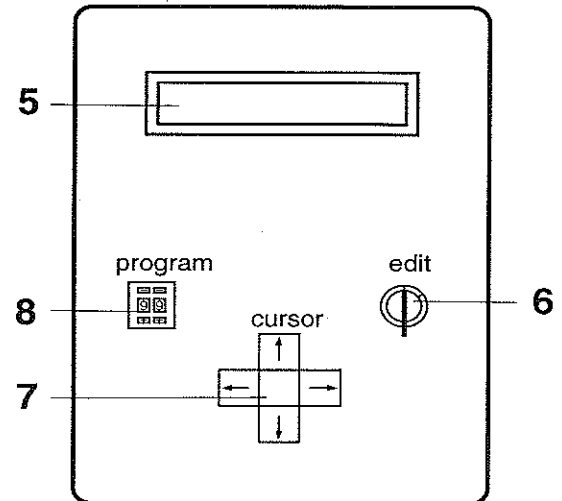



Entries are only possible if:

- key switch "edit" (6) is switched on.

Selection of test program parts:

First the selected program number (0 - 50) can be seen on the visual display (5).

By pressing cursor key  the test program part will be "paged down" by one test program part respectively until returning to the start of the menu.

By pressing cursor key  "paging up" is possible.

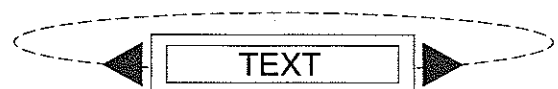



Operation and Function of Parameter Input Unit

To enter test parameters:

The entry of test parameters is analog to the selection of the test program parts.

By pressing cursor key  the respective test parameter increases in value.

By pressing cursor key  the respective test parameter decreases in value.

 By keeping the arrow key pressed the test parameters are being continuously "paged" (auto repeat).

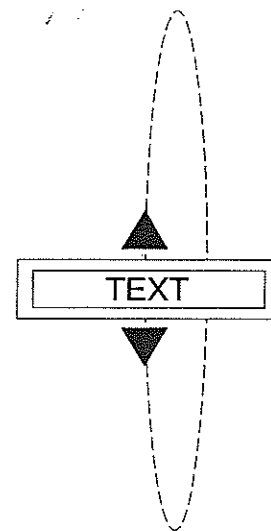

To acknowledge entries:

If a test parameter has been changed according to the above procedure then the new value blinks in the visual display (5).

To adopt the value press the middle (red) key (ENTER) (7) of the key panel "cursor".

After acknowledgement the new value will be indicated.

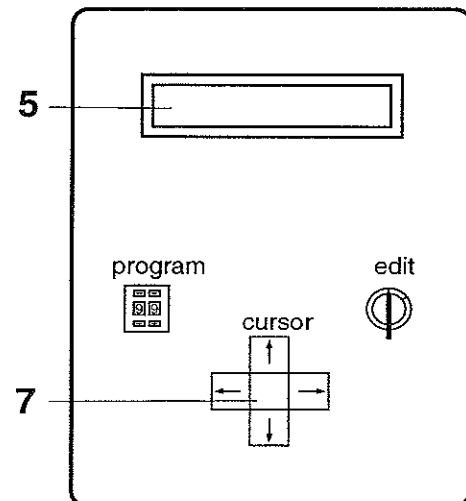

To deactivate a test program part

To deactivate a test program part, i.e. not to execute same during a test run, a **determining** test factor has to be set on 0.

A determining test parameter e.g is the time. If the test time is being set = 0 then the corresponding test program part will not be considered during testing.

To Enter Test Program

For summary of the test program parts, please see annex.

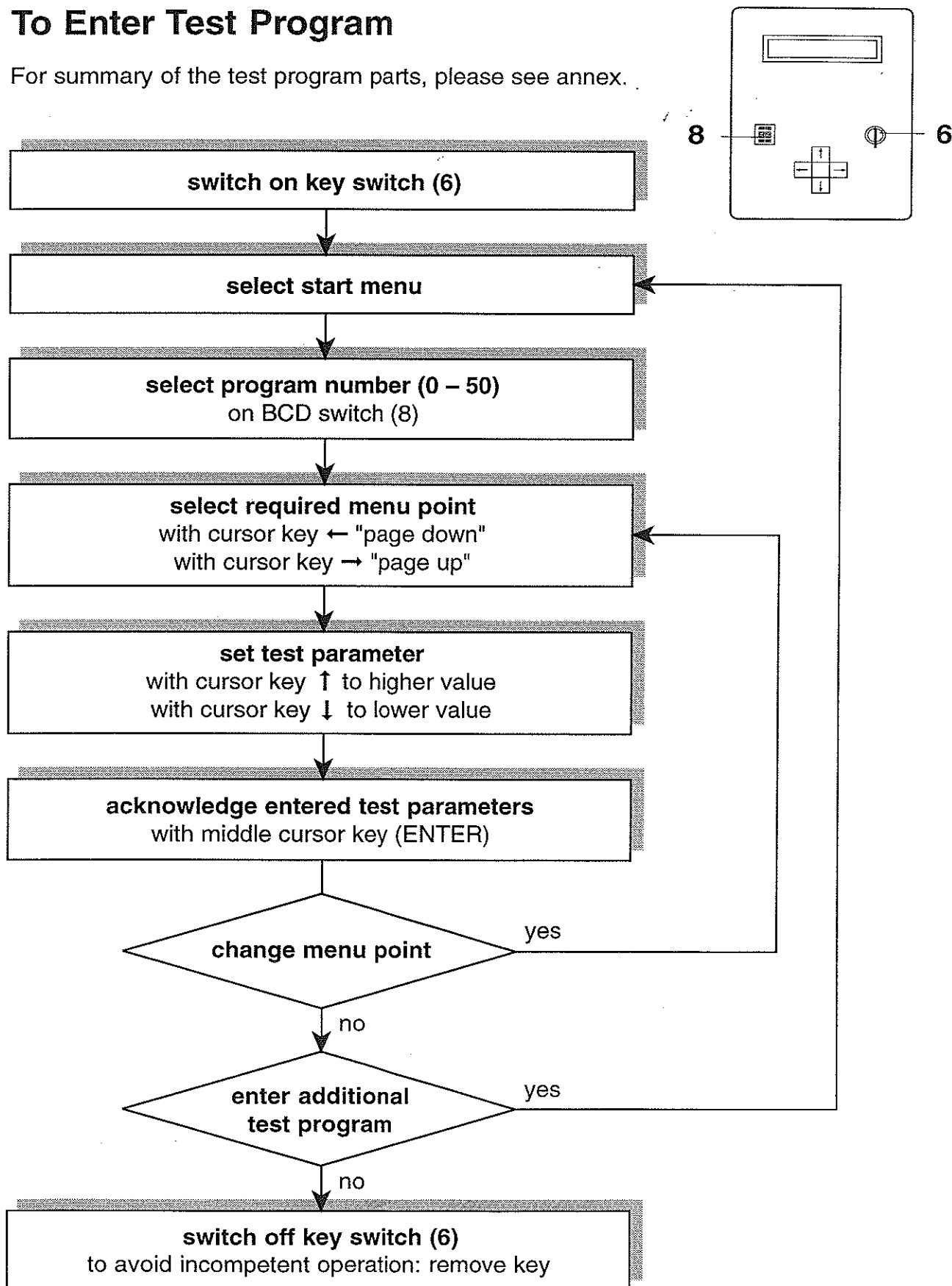

Test program -00-

If the test program switch is in -00- position, the test cycle is as follows:

- Setting of chosen test times via cursor.
- Tests are started without prior determination of number and cross section (EN 60204) of protective wire test points.
- For each protective wire test point, the used cross section is set via hand key.
- If all test points of a test type are worked off, please activate the next test type (insulation resistance measurement) by pressing the key "ack".

The number of test points for program -00- is practically unlimited.

Testing

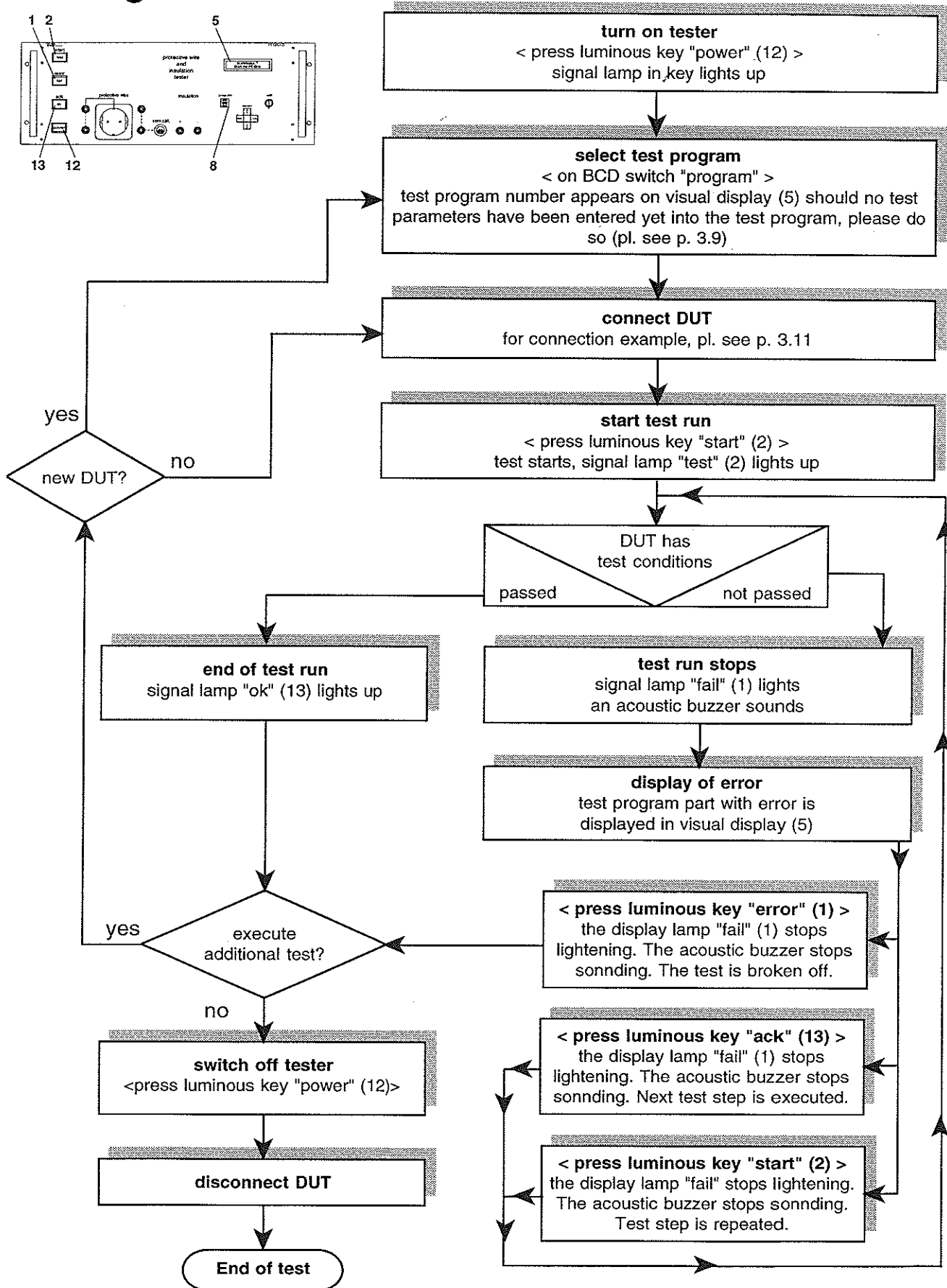
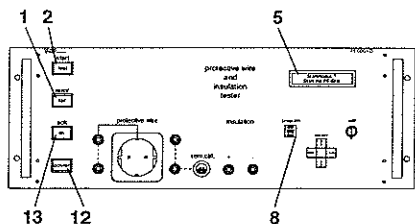



To Connect DUT

 If the DUT is provided with a **power switch (a)**, same must be closed!

1. Protective wire tests

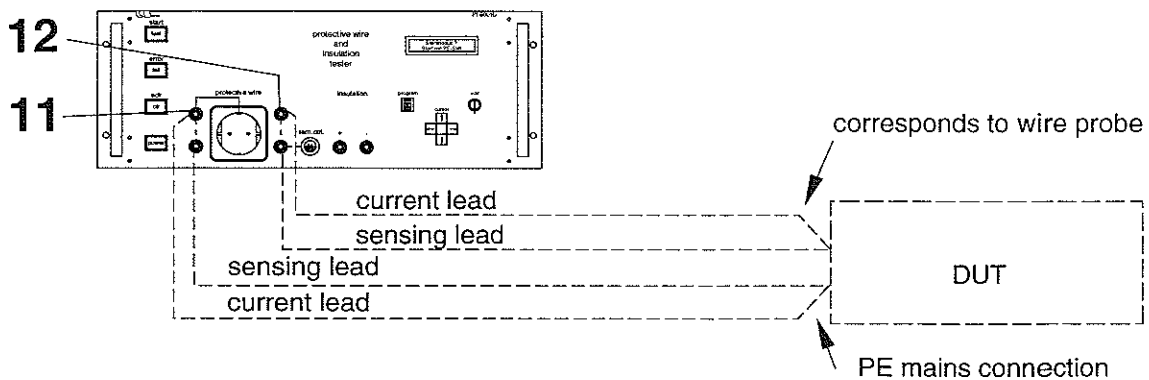
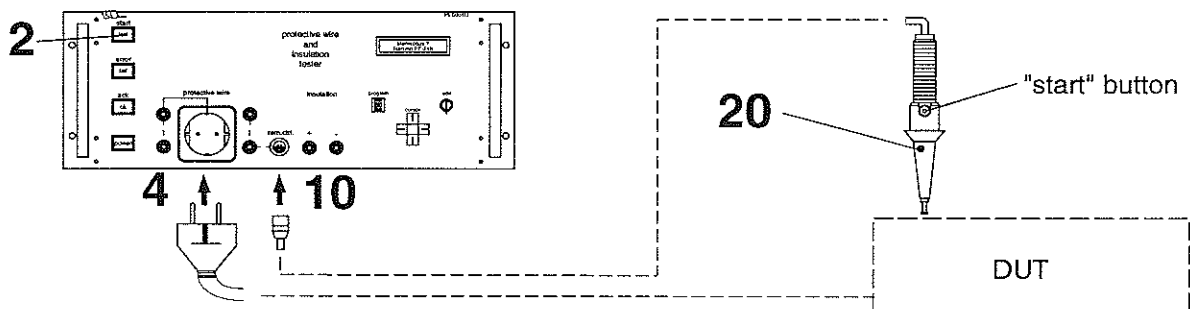
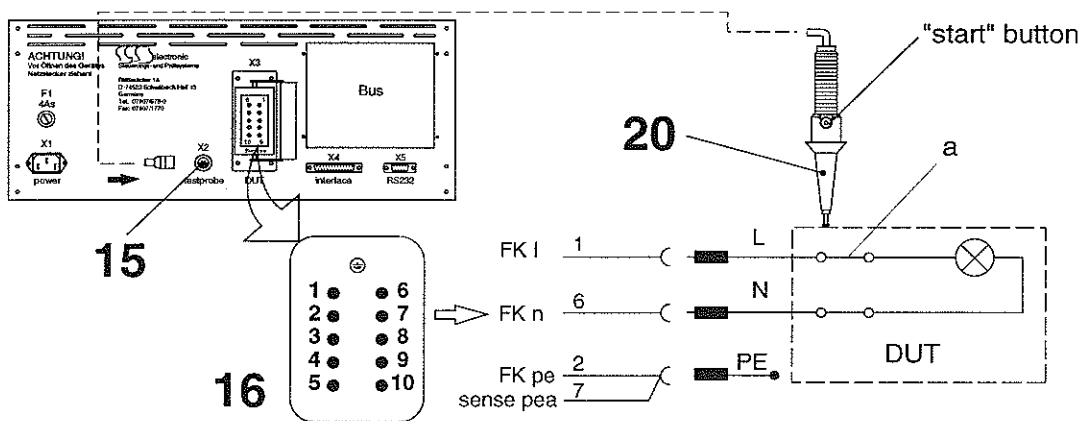
- connect DUT via socket DUT (16), via protective contact socket (4) or manually via safety laboratory sockets (11+12).
- hold test pin of protective wire probe (20) to housing of DUT.
- actuate "start" key on protective wire probe (20), or "start" key (2) on tester, or work with "auto start".



 If the test probe PE 13-i is used, operation only with "auto start" or start key (2) on front panel possible.

2. Insulation measurements

- Connect DUT via socket DUT (16), via protective contact socket (4), or via safety laboratory sockets (11).
- Test of power lines automatically via socket DUT (16), protective contact socket (4) safety or laboratory sockets (11).
- Additional tests with protective wire test probe PE 13-i or PE 15-i possible (EN 60204/VDE 0113).

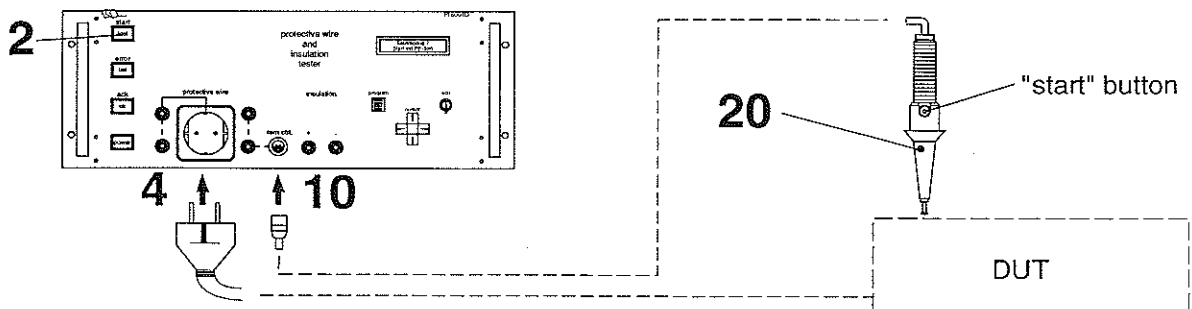
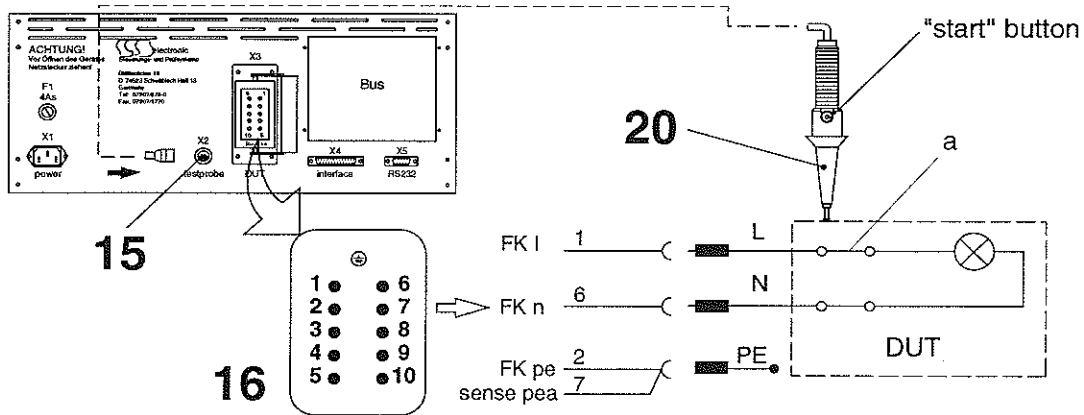

Contents - Chapter 4

Measurements, weight and performance data 4.1

Fuses 4.1

Interface configuration

socket protective wire probe 4.2

socket DUT 4.3

socket for interface 4.4

socket RS 232 4.5

Measurements, Weight and Performance Data

Measurements

width: 540 mm
 depth: 410 mm
 height: 205 mm
 plug-in: (19" / 4 HU)

Weight

gross: approx. 175 N

Power supply

voltage: 230 V / 50 Hz \pm 10%
 frequency: 50 Hz - 60 Hz
 power: approx. 500 VA
 fuses: 4 A slow at 230 V

Insulation test

test voltage: 500 VDC
 1000 VDC
 measuring range: 5 MOhm
 50 MOhm



safety current limited

Protective wire test PI 6001D

test current: > 10 AAC
 up to 0.3 Ohm
 measuring range: 0.3 Ohm
 3 Ohm



protective low voltage

Protective wire test PI 6011D

test current: > 25 AAC
 up to 0.1 Ohm
 measuring range: 0.3 Ohm
 3 Ohm



protective low voltage

Device fuses

fuses for tester:
 rated voltage 230 VAC: 4 A

Interface Configuration

1. Connection sockets for protective wire probe "testprobe" and "rem.ctrl"

pos. 10 and 15

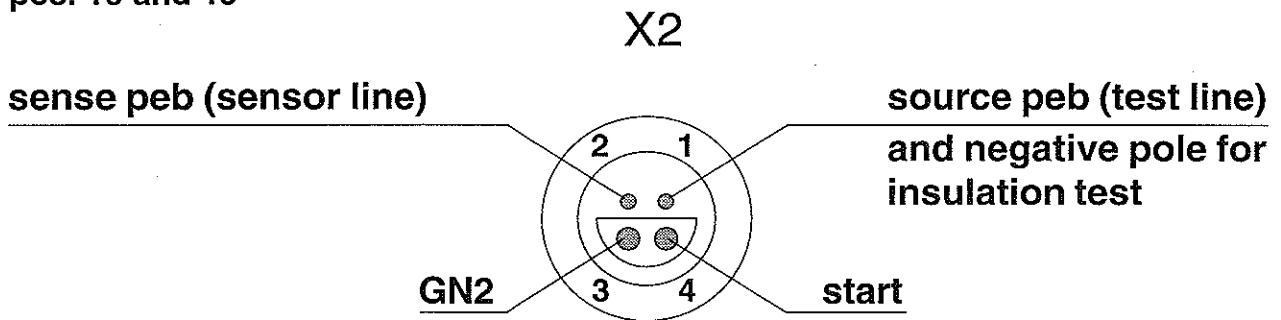

PIN	Description	Configuration
1	GN2	reference potential for control signals
2	start	start signal for "start" key on protective wire probe
3	source peb (test line)	power line to protective wire test point and negative pole for the insulation test.
4	sense peb (sensor line)	sensor line to protective wire test point

Interface Configuration

2. Socket DUT

pos. 16

X3

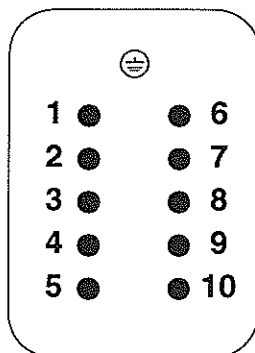

PIN	Description	Configuration
1	FK I	DUT-power connection phase I
2	FK pe source pea	DUT-power connection protective wire pe
3	source peb (PE – probe)	power line to protective wire test point (parallel to protective wire test probe) and negative pole for insulation measurement
4	–	no configuration
5	GN2	reference potential for start signals
6	FK n	DUT-power line neutral wire
7	sense pea	sensor line to DUT-power connection PE for protective wire
8	sense peb	sensor line to protective wire test point
9	–	no configuration
10	start	for external start signal

Interface Configuration

3. Plug for Interface

pos. 17

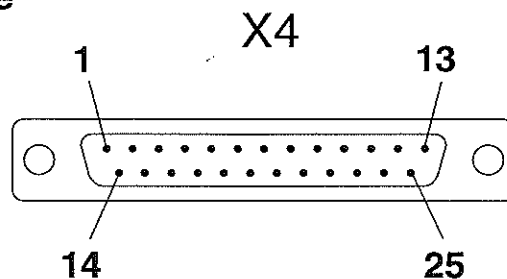

PIN	Description	Configuration
1	GND	reference potential for serial interface
2	TxD	transmit data, transmission data of serial interface
3	Start	input "start"
4	Error	input "error"
5	RE2	reserve input 2
6	La. Pr.	output signal lamp "test"
7	La. Feh.	output signal lamp "fail"
8	–	no configuration
9	–	no configuration
10	GNS	reference potential for control signals
11	+ 24 V	control voltage + 24 V
12	V _{cc} in	feed-in for output driver (+ 24 V)
13	–	no configuration
14	GND	reference potential for serial interface
15	RxD	receive data, receive data for serial interface
16	Quitt.	input "ack"
17	HT 03	input hand key
18	Summer (buzzer)	output buzzer
19	La. Gut (Pass)	output signal lamp "ok"
20	RA 1	reserve output 1
21	–	no configuration
22	–	no configuration
23	GNS	reference potential for control signals
24	+ 24 V	control voltage + 24 V
25	V _{cc} in	feed-in for output driver (+ 24 V)

Interface Configuration

4. Socket RS232

pos. 18

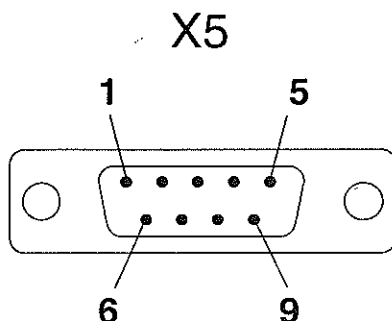

PIN	Description	Configuration
1	–	no configuration
2	RxD	receive data
3	TxD	transmit data
4	–	no configuration
5	GND1 and GND2	reference potential of serial interface
6	–	no configuration
7	–	no configuration
8	–	no configuration
9	–	no configuration

Interface Parameter RS 232	
Baud Rate	9600 bps
databits	8
parity	none
startbits	1
stopbits	1
XON / XOFF	switched off
handshake	no hardware and no software handshake

Contents - Chapter 5

Basic Settings	5.1
Programmable Parts of Test Program	5.2
Address for Service	5.3
Spare Parts	5.3
Accessories	5.4
Important Regulations and Standards	5.5
Guarantee Terms	5.6

Basic Settings

Description	Parameter settings	Remarks
Selection of test program	< only with key >	if set on "only with key", then another test program can be selected only after turning key switch "edit" (6)
Serial interface	< for protocol printer > EPSON < for label printer > STAR < for data acquisition > with PC	setting of connected device on serial interface
Language	< GERMAN > < ENGLISH >	setting of respective native language being used on visual display
Information buzzer	< yes > < no >	if set on "yes" a short buzzing sound can be heard after errorfree test
Protocolling	< always > < never > < error >	setting of printer, under which conditions a printout is wanted
Operating mode	< manually > < automatically via RS 232 >	operation via front panel. Device controlled via serial interface only (description on request)
Protective wire	< resistance measurement > < according EN 60204-1 >	device measures protective wire resistance. Voltages drop accord EN 60204-1 (VDE 0113) is measured and evaluated.
Current program version	< 1.00 16.08.1994 > (example)	display of current installed software version – e. g. as service information



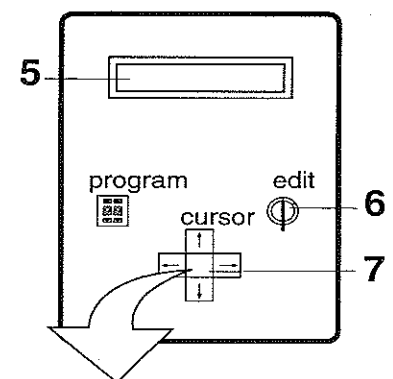

How to change basic settings

- Turn key switch "edit" (6) to the right.
- Keep the three middle keys on the keypad "cursor" (7) pressed simultaneously for 5 seconds.
- On visual display (5) the menu for basic settings will appear.



To change settings (see chart)

Example: change of native language

- Select native language via  key or  key.
- Select via  key or  key the required setting parameter, e.g. "ENGLISH".
- Acknowledge set values with middle red key (ENTER) of panel "cursor" (7).
- Select additional setting possibilities or
- end entry → by turning key switch (6) to the left

keep pressed for 5 seconds

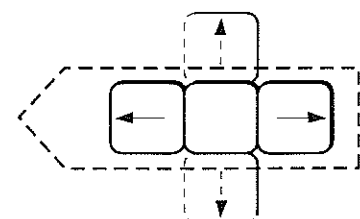

Programmable Test Program Parts

Test Program	Test Program Part	Test Parameter	Stepping Width	Remarks
start mode ?	start with PE-probe	–	–	enter required starting mode
	autostart	–	–	
Protective wire test (PE)	number of PE tests	1 – 99	1	enter required number of tests
	PE test time	0 – 10 s	100 ms	enter required test time
	R _{max}	0.00 – 3.00 Ω (2 ranges)	10 mΩ	enter upper threshold
	Cross section PE 1	1.0 mm ² 1.5 mm ² 2.5 mm ²		enter cross section of corresponding test point
	Cross section PE 99	4.0 mm ² >6 mm ²		
Test current	small medium large		for straining of test current	
Insulation test (IS)	number IS test	1-255	1	enter required number of tests
	test time	0.0 – 20.0 s	100 ms	enter required test time
	test voltage	500 VDC	–	acknowledge required value
		1000 VDC	–	
	R _{min}	0.5 – 50.1 MΩ (2 ranges)	100 kΩ	enter lower threshold

Service Address

SPS electronic GmbH
Blätteräcker 18
D - 74523 Schwäbisch Hall - Sulzdorf

Telephone: (7907) 878-0
Service: (7907) 878-29
Telefax: (7907) 1770

Spare parts

In case of ordering spare parts please quote as specified below:

- Name of test device
- Article-number
- Article-name
- Order-number (Type)
- Required number per article

Article	Type	Device contains
plug-in housing	EH 1904-y	1
PE-probe (protective wire probe)	PE 13-i/PE 15-i	1
transformer supply	LG 60	1
transformer test	PX 61	1
processor board	CPU 30	1
measuring board	MF 600	1
insulation measuring board	IS 600	1
supply board	VS 600	1
relay board	Rel 600 a	1
alpha-numerical visual display	T 20 A	1
cursor keys	Cursor 60	1
BCD-switch 2-digit		1
buzzer		1
key switch		1
luminous switch		1
luminous pushbutton		3

Spare Parts

Article	Type	Device contains
Fuse 4 As		1
IEC 320 connector (cold appliance plug)		1
Socket for test probe	BU 04-i	2
Socket for DUT, 10-pole	BU 10-n	1

Accessories

No.	Description
EH 1904-y	plug-in housing 19"/4HU
PE 13-i	protective wire test probe small, without start button
PE 15-i	protective wire test probe large, with start button
VK 60	extension cable for test lines, approx. 1.5 m long
ST 10-n	plug for test voltage acceptance
ST 09-d	plug for RS 232 interface
BU 25-d	plug for parallel interface
ST 04-i	plug for connection to protective wire test probe
IE 64-g	separation of potential for interface
PA 60	socket adapter (please state plug standard, e.g. if earthed or similar)
PA 63-3	adapter for screw-type terminal 3-pole
PA 63-5	adapter for screw-type terminal 5-pole

Important Regulations and Standards

Safety Regulations	"General Safety Regulations" (VBG 1)
Safety Regulations	"Electrical Systems and Production Facilities" (VBG 4)
Safety Regulations	"First Aid" (VBG 109)
DIN VDE 0100	"Regulations for Installation of Power Plants with Rated Voltages up to 1000 V"
DIN VDE 0104	"Installation and Operation of Electrical Test Systems"
DIN VDE 0106 part 1	"Protection against Electric Shock. Classification of Electrical and Electronical Production Facilities"
DIN 40 008 part 3	"Safety Labels for Electrical Engineering; Warning Notices and Additional Notices"
DIN 40 050	"IP-Protective Systems; Contact-, Foreign Material- and Water-Protection for Electrical Production Facilities"

Guarantee Terms

■ **Guarantee validity**

12 months after delivery.

■ **Guarantee claims can only be accepted provided that**

1. The test device has to be set into operation by qualified personnel at the client's premises.
2. Checks must be executed annually and properly (by SPS electronic GmbH).
3. Faulty or worn parts must be replaced at once. Safety regulations prohibit operation with such parts.
4. Faulty parts with a guarantee claim have to be presented to SPS electronic GmbH for checking.
5. Any occurring faults must be reported immediately to SPS electronic GmbH.
6. The connecting lines leading to the tester must be installed properly before starting operation (these operations are excluded from the delivery conditions).

■ **Begin of guarantee**

Guarantee will begin on the date stated in the delivery note of the device.

■ **Guarantee services**

SPS electronic GmbH guarantees that the test device will function properly, that it has been produced with care and by qualified personnel and that only materials of high quality have been used.

All parts will be replaced free of charge which, within the validity of guarantee, become faulty or useless due to inadequate materials, production faults or faulty design.

■ **Excluded from guarantee**

1. Damages due to circumstances beyond our control, mainly improper handling or local conditions.
2. Damages to devices from which the serial number has been removed, destroyed or manipulated.
3. Parts that wear easily like fuses, signal lamps, etc.