

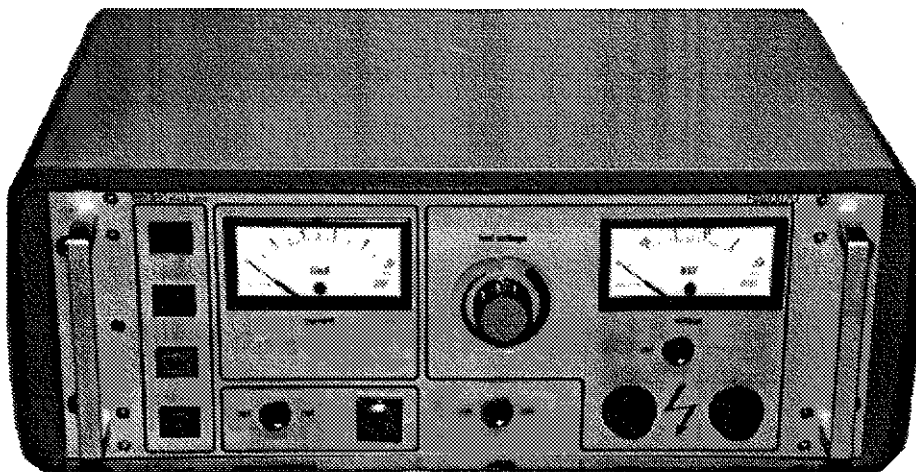





Operating Manual

for high-voltage testing devices HA4000A and HA4001A



	Liability	Chapter 1
	For your Safety	Chapter 2
	Operation	Chapter 3
	Technical Data	Chapter 4
	Appendix	Chapter 5



The personnel being entrusted with the inspection work as well as the persons responsible for the same must have understood this operating manual, especially the chapter "For your Safety"!

For a quick putting into operation, an **abridged manual** has been filed under page 3.5 (HA4000A) and 3.6 (HA4001A) respectively. This abridged manual can be kept at the place of testing. Yet it is only allowed to be used after having completely read and understood this detailed operating manual.

Please enter the
serial number

of your high-voltage testig device here so that it will be ready on hand for any guarantee claim or query:

--	--	--	--	--	--	--	--

There is no warranty for devices without the original serial number!

You will find the serial number here

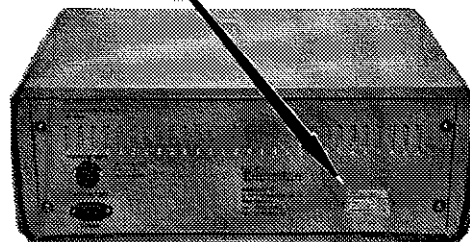

Position as of 3/1992

This operating manual has to be treated as confidential.

It is exclusively destined to be used by the authorized personnel within your plant.

Allowing a third party to use this manual is not permitted and will be subject to indemnification.

All rights, including translation rights, are preserved. No part of this operating manual is allowed to be reproduced or processed by means of electronic systems, copied or distributed without the written approval by SPS electronic GmbH.

 **You will be liable for any inappropriate use!**

- The high-voltage testing devices have been built according to state of art technology, tested and are thus reliable. Nevertheless, dangers may occur when operating the units in an inappropriate way.

 **Please take therefore your time to study this operating manual in all details!**

- The liability for the function of the high-voltage testing device will in any case be transferred to the owner or operator if the device has been inappropriately maintained or repaired by persons not being authorized by SPS electronic GmbH or if a handling practice has been used which is not adequate for the intended use (see chapter "Intended use" page 2.4).
- The operator is obliged to operate the high-voltage testing device only in perfect condition.
- SPS electronic shall be liable for any defect or omission within the frame or warranty, as stipulated in the order confirmation, any exceeding claim being excluded.
- We reserve the right of technical modifications in order to further develop and improve our products at any time. Such modifications as well as mistakes or printing errors shall not be subject to indemnification.
- Exclusively original SPS electronic GmbH spare parts and accessories are allowed to be used.
- SPS electronic GmbH shall not be responsible for any damage caused by the non-observance of the instructions contained in this operating manual. Warranty and liability conditions of the terms and conditions of SPS electronic GmbH are not enhanced by the above notes.

SPS electronic GmbH
Blätteräcker 18
D - D-7170 Schwäbisch Hall-Sulzdorf/Germany

Telephone: (07907) 878-0
Service: (07907) 878-25
Telefax: (07907) 1770

List of Contents Chapter 2

Safety-at-Work Symbols	2.1
Safety Instructions	2.2
Testing	2.2
Personal requirements	2.2
Organizational requirements	2.2
Technical requirements	2.3
Intended Use	2.4
Safety Equipment	2.4

Safety-at-Work Symbols



This symbol warns against dangerous electric voltage, involving danger to life and limb.

Please follow these instructions and be in these cases especially careful.

In addition to the instructions contained in this operating manual, the general safety instructions and the regulations for preventing accidents have to be adhered to.



This symbol warns against danger to life and limb.

Please follow these instructions as well and be also very careful in these cases.

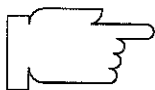

This symbol gives you important additional information.

Safety Instructions



Caution! Danger to life!

- Unplug mains plug before proceeding to open the device.
- Do never repair or bridge fuses or other components required for the safety.

■ Testing

Do not start testing before having arranged for **all** safety precautions and until they have been checked by the person responsible for the testing.

■ Personal Requirements

Only such electricians and electrotechnically trained personnel being qualified by their reliability, their sense of responsibility and their adequate understanding for existing and possible dangers should be entrusted with the testing. They must be acquainted with the relevant regulations for preventing accidents and the generally recognized regulations of technology (you will find an outline of the most important regulations and standards in the appendix).

Please follow the VDE safety regulations when working with high voltage!

■ Organizational Requirements

The test place being equipped with a high-voltage testing device HA4000A or HA 4001A is only allowed to be operated under the direction and supervision of a qualified electrician.

All persons, except those being directly involved in the testing works, must have left the test place being marked and limited by warning signs and warning lamps when preparing the high-voltage testing device HA4000A or HA 4001A for being switched on.

Any fault or defect at the device or at electrical and testing equipment has to be reported to the superior in charge immediately. The testing works must be discontinued until having remedied the fault or defect.

This operating manual has to be kept in the proximity of the device so that it is **at any time** immediately accessible for the personnel working with the device.

Safety Instructions (continuation)

■ Technical Requirements

Arrangement of a test place without positive protection against contact¹

(Extract from the Code of Practice for Preventing Accidents, edition 4/89 of the employer's liability insurance company of the light and electrical engineering industries, Cologne/Germany).

With test prods

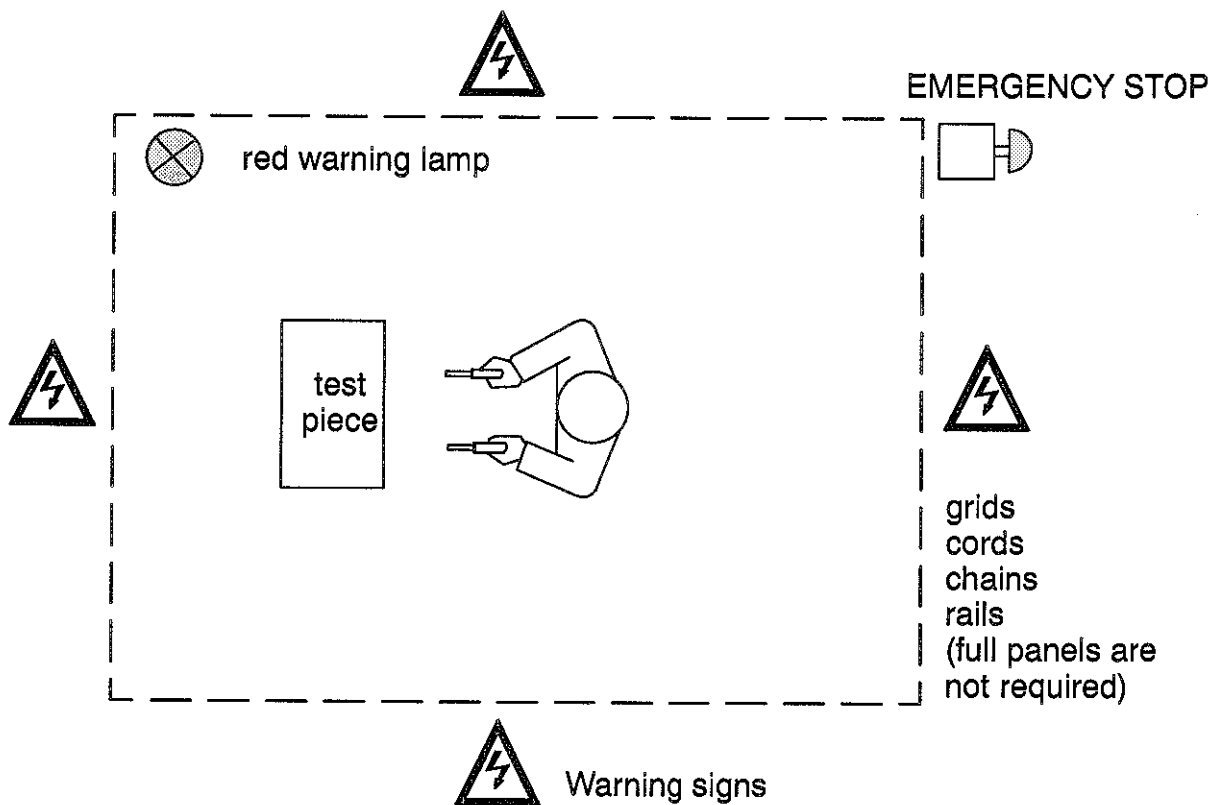

Cleanliness and an easy-to-survey arrangement of the test place has to be ensured by appropriate instructions and checks!

1. Test places without positive protection against contact are test places where parts of the test piece or active parts of the testing device are not completely protected against contact during testing.

Intended Use

■ Application Possibilities

The high-voltage testing device HA4000A or HA 4001A has been developed for checking air and leakage paths in electric appliances and systems. These paths can be measured according to the recommendations VDE 0110 and IEC 384 respectively.

Additional application possibilities:

- In laboratories and manufacturing
- As potential-free voltage source
- In some cases, especially when testing electronic assemblies, high-voltage cannot be switched on or off immediately. If the voltage has to be raised continuously to a set value, a run-up device of the HA 8002 AD / HA 8010 A series or the D.C. testing device HA 6010D has to be used.



The high-voltage testing device HA4000A or HA 4001A has to be operating according to the enclosed operating manual. Any other use is considered to be not intended. The supplier shall not be liable for any damages resulting from such a not intended use; the operator shall in this case be fully responsible for the risk involved.

The following is only allowed with the expressive consent by SPS electronic GmbH:

- Elektric coupling with devices not being mentioned in this operating manual.

Protective Equipment

- Potential-free voltage
- Transformer and measuring transducer with double insulation
- Dual status indicator
- Externer warning lamp set upon request
- Four switching-on states
- Integrated warning buzzer
- Two independent cut-off circuits
- Protective-type connecting sockets

List of Contents Chapter 3



Be aware!

You are responsible for the safety within the working range of the high-voltage testing device. For this reason, please follow under all circumstances the "For your Safety" instructions given in chapter 2, passing on the information to all persons working in that area

Operating Elements

Front panel	3.1
Rear panel	3.3
Accessories	3.4

Putting into Operation

Abridged Manual HA4000A	3.5
Abridged Manual HA4001A	3.6
Mains connection	3.7
Switching-on	3.8
Select operating mode (HA4000A only)	3.9
Select voltage range (HA4000A only)	3.9
Set tripping current	3.9
Set test voltage	3.10
Set operating mode (HA4000A only)	3.10
Connect test piece	3.11
Testing with high-voltage	3.12
Switching-off	3.12
Operating mode	3.13

Operating Elements - Front Panel

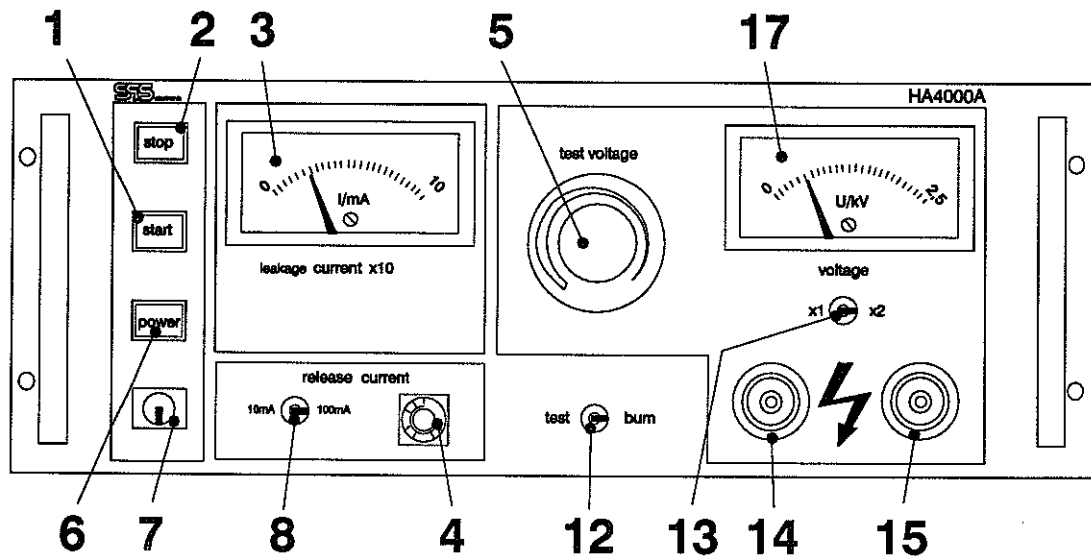

Item	Designation	Function	HA 4000A	HA 4001A
1	"Start" button	Preparing for operation	X	X
2	"Stop" button	Interrupts the high-voltage supply via two separate circuits. This button also serves as a kind of emergency stop switch . <u>Automatic interruption:</u> As soon as the current limit set at the potentiometer (4) is exceeded: 1 mA – 100 mA 0.05 mA – 0.5 mA	X	X
3	Display unit "current" (Strom)	Display of the current values achieved in mA. Fix range 100 mA Fix range 0.5 mA	X	X
4	Potentiometer	Setting of tripping current: 1 mA – 100 mA 0.05 mA – 0.5 mA The tripping current must exceed the limit value of the set testing range by 10 % , i.e. in toggle switch position "x1" at least 1 mA in position "x10" at least 10 mA .	X	X
5	Control knob "test voltage" (Prüfspannung)	Setting of test voltage 0 – 2,5 kV 0 – 5 kV	X X	X
6	"Power" (Netz) button	Switching-on of device.	X	X

Operating Elements - Front Panel

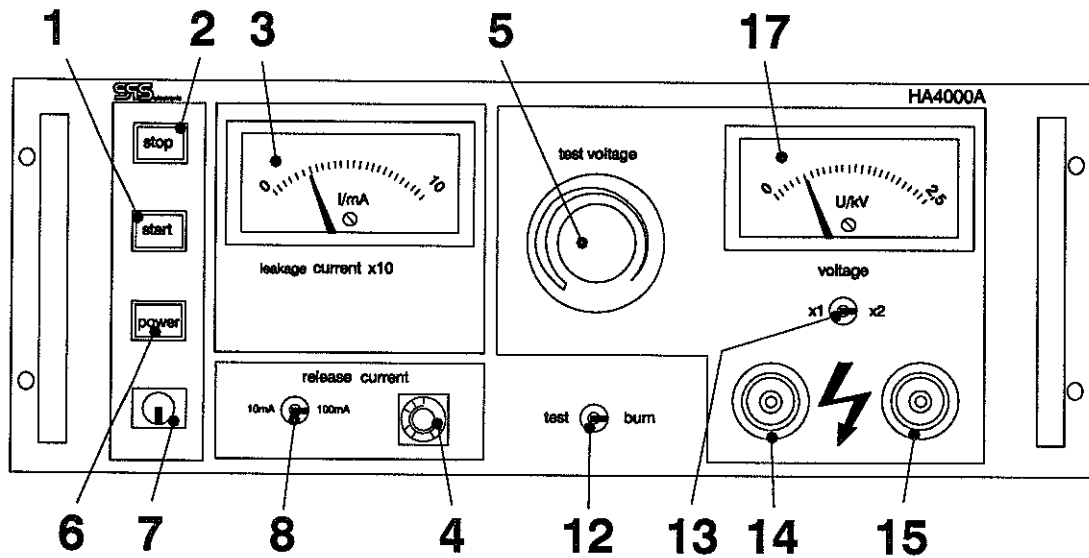

Item	Designation	Function	HA 4000A	HA 4001A
7	Key switch	Protection against unauthorized use.	X	X
8	Toggle switch 10 mA/100 mA	To change range of tripping current. <u>Switch position Range</u> 10 mA 1 mA – 10 mA 100 mA 10 mA – 100 mA	X	
12	Operating-mode toggle switch	Setting of operating mode.	X	
13	Toggle switch x1/x2	To change range of test voltage. <u>Switch position Range</u> x1 0 kV – 2.5 kV x2 0 kV – 5 kV	X	
14	High-voltage connection	Connecting socket for test pistol.	X	X
15	High-voltage connection	Connecting socket for test pistol.	X	X
17	Display unit "voltage" (Spannung)	Display of obtained voltage values in kV.	X	X

Operating Elements - Rear Panel

In connection with housing - accessory EH 1904-h

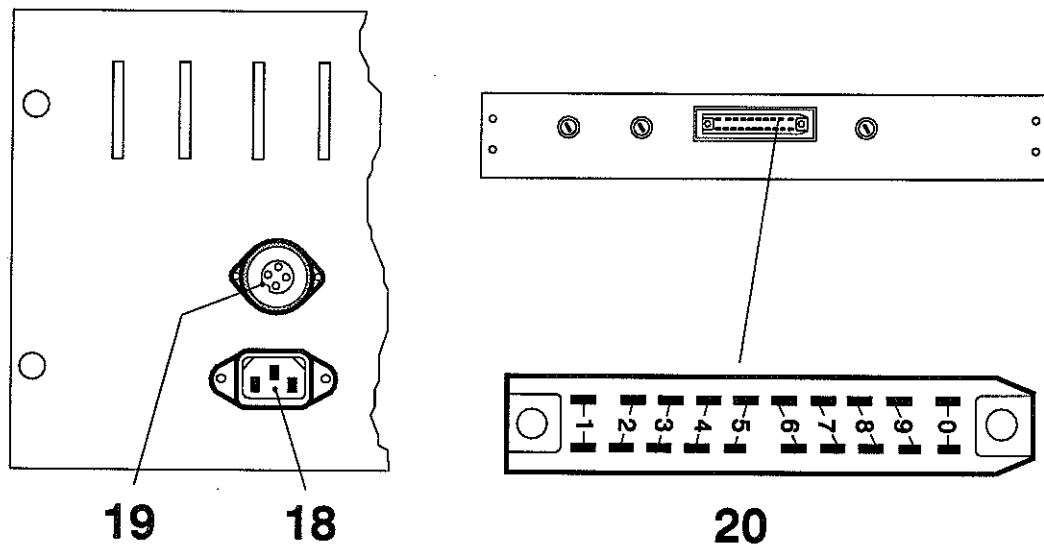

Item	Designation	Function
18	Cold-appliance socket	Mains supply (230 V / 50 cycles)
19	Warning lamp connecting socket	Connection possibilities for external warning lamp set (accessory WL 22) (pin allocation see page 4.6)
20	Plug-in interface	Mains and warning lamp connection (Pin allocation see page 4.4)

Operating Elements - Accessories

External warning lamp set (22)

Model: WL 22



Caution! Danger to life!
The connection is made
with mains voltage (230 V)

Connection: At warning lamp-
connecting socket (19)

Function: Display of operating
mode

Pin allocation see page 4.6

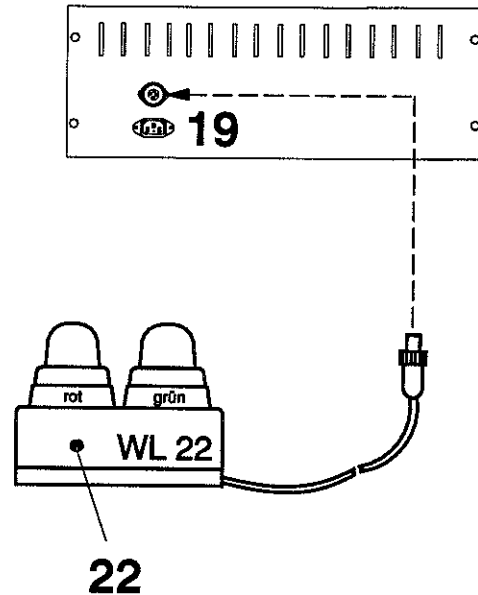

Test pistols (23)

Model: SP 02

Connection: At the two high-
voltage connection
sockets (14, 15)

Function: Transfer of test-
voltage to test piece

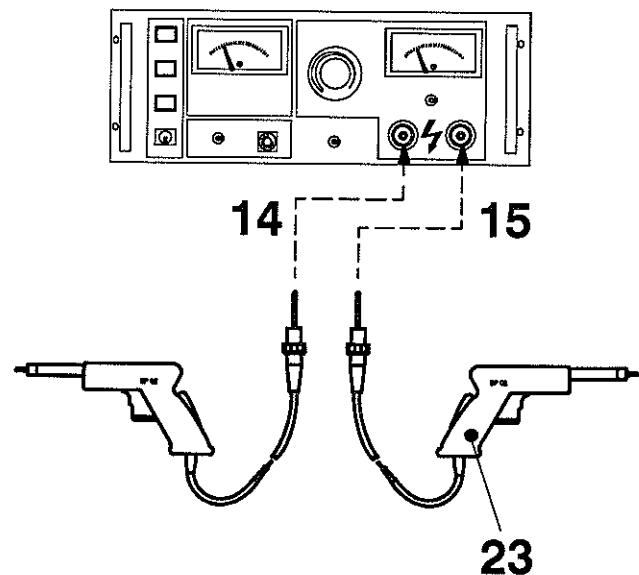



Abridged manual for a quick putting into operation. HA4000A

Please only use this abridged manual after having read and understood the whole operating manual!

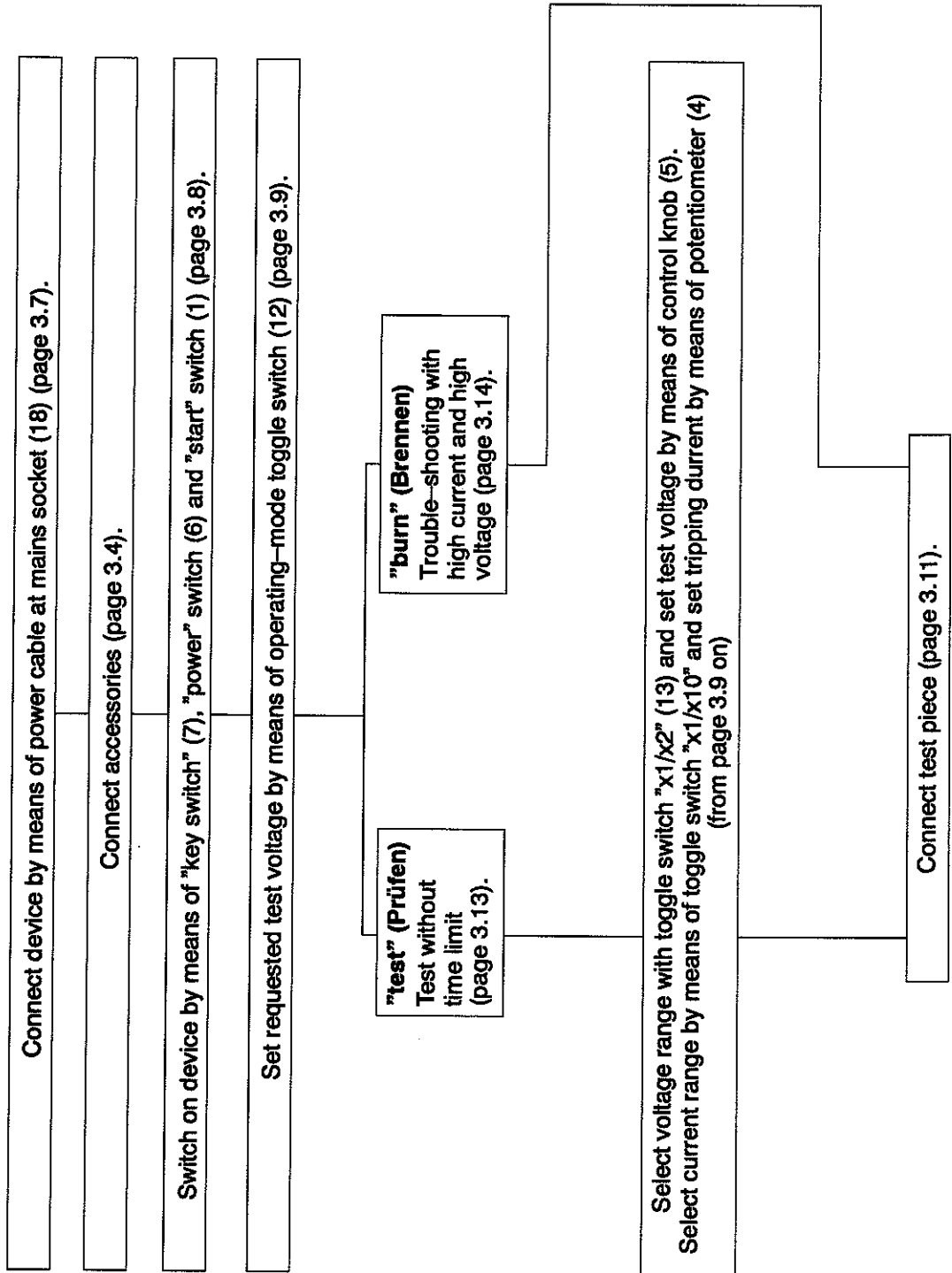



Abridged manual for a quick putting into operation. HA4001A

Please only use this abridged manual after having read and understood the whole operating manual!

	Connect device by means of power cable to mains socket (18) (page 3.7).
	Connect accessories (page 3.4).
	Switch on device by means of "key switch" (7), "power" switch (6) and "start" switch (1) (page 3.8).
	Set tripping current by means of potentiometer (4) (page 3.9).
	Set test voltage by means of control knob (5) (page 3.10).
	Connect test piece (page 3.11).

**Be aware!**

You are responsible for the safety within the working range of your high-voltage testing device. For this reason, please follow under all circumstances the "For your Safety" instructions given in chapter 2, passing the information on to all persons working in that area.

Mains connection

Insert mains plug for current supply



Caution, working with electric current means danger to life!

- Plug power cable into socket of the device (18) (on the rear panel of the device) and into
- mains socket with 230 V / 50 cycles.

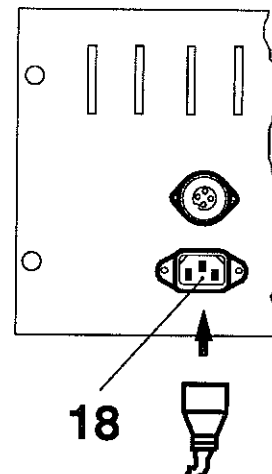

Switching-on

- Turn key switch (7) clockwise
- Press "power" (Netz) button (6)

Actuating

- key switch (7) and "power" (Netz) button (6) causes

the lighting-up

- of the yellow signal lamp of the "power" (Netz) button (6),
- of the green signal lamp of the "start" (Start) button (1), as well as
- of the green lamp of the external warning lamp set (22) (accessories)

sounding additionally

- an audible alarm which indicates that high-voltage is not yet available. This is to avoid a testing without voltage.

- Pressing the "start" button (1)

extinguishes

- the green signal lamp of the "start" button (1)

and lights up

- the red signal lamp of the "stop" button (2)
- as well the red lamp of the external warning lamp set (22) (accessories).

The audible alarm will go off.



The high-voltage testing device will then generate high-voltage!

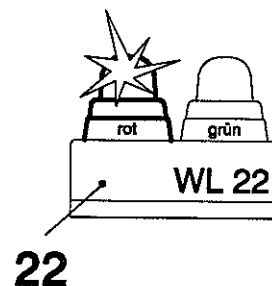
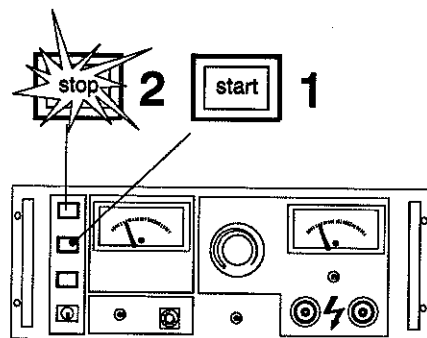
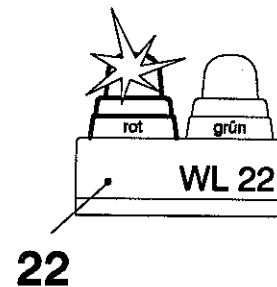
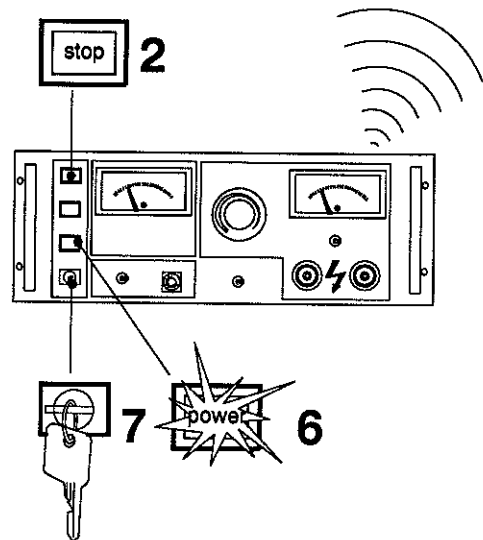

Select operating mode

(HA4000A only)

- Set operating-mode toggle switch (12) to the requested operating mode.

 The individual operating modes are described from page 3.13 on.

 If the operating mode "burn" is selected proceed with "connect test piece".

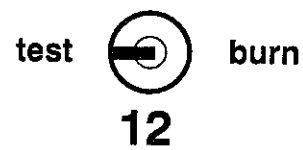
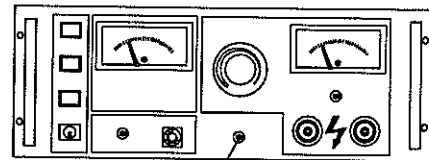

Select voltage range

(HA4000A only)

- Select toggle switch "x1/x2" (13) to the desired range:

x1 = 0 - 2.5 kV

x2 = 0 - 5 kV

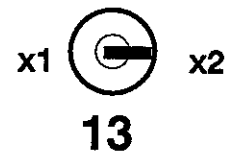
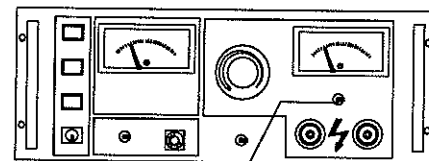

Set tripping current

- by means of tripping current potentiometer (4).

 Tripping current >10 % of the limit value of the set test range, i.e.

for HA 4001A at least 0.05 mA

with HA 4000A

in toggle switch position

"10 mA" at least 1 mA

in position

"100 mA" at least 10 mA.

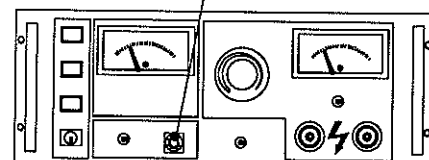

Set test voltage

- Set test voltage (Prüfspannung) (5) by means of "test voltage" control knob to the desired test voltage.

➡ The test voltage should be > 10% of the limit value of the set test range, i.e. in toggle switch position
 "x1" at least 0.25 kV in position
 "x2" at least 0.5 kV

➡ The set test voltage is shown at the "voltage" (Spannung) display unit (17).

➡ As the test voltage depends on the mains voltage, the correct high-voltage value should be checked regularly.

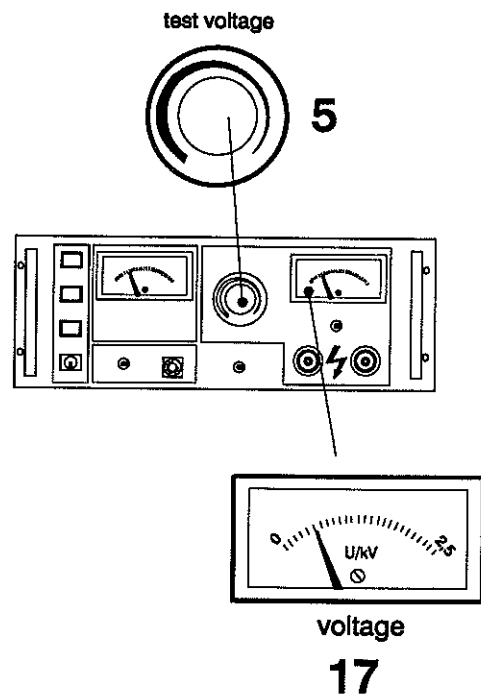

Connect test piece



In the operating modes "test" (Prüfen) and "burn" (Brennen) high-voltage is transferred as soon as the test pistols are connected!



If the test piece is provided with a **mains switch (1)**, the same must be closed!

- Extend test prods of the high-voltage test pistols (23) by pressing both safety buttons (2 and 3) simultaneously.
- Connect test piece via the high-voltage test pistols (23).

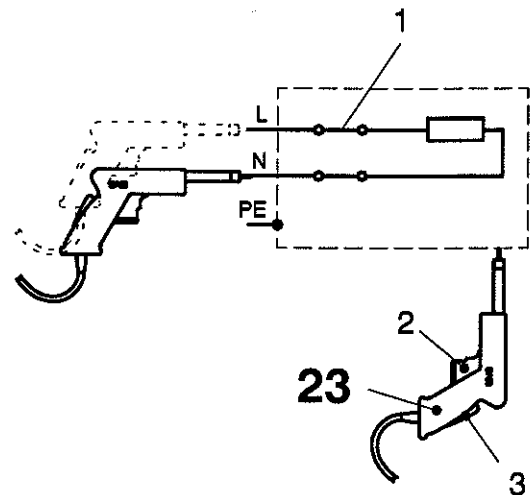

For test pieces with line filters:

- The voltage can be increased manually.
- Use run-up devices (HA 8002AD).
- Use D.C. units (HA 6002D, HA 8002AD or HA 6010D).

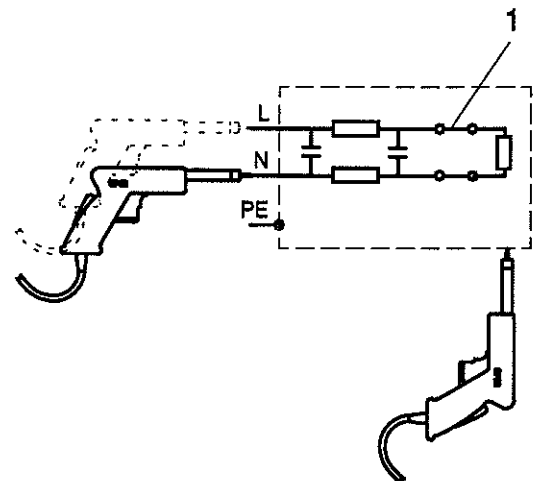

Testing with high-voltage

The requirements for the generation of a high-voltage by the high-voltage test device are:

- Mains voltage available
- Key switch (7) switched on
- "Power" (Netz) button (6) switched on
- "Start" button (1) actuated
- Tripping current > 10 % of the limit value of the set range.
- Test voltage > 10 % of the limit value of the set range.

Switching-off

- Press "stop" (Stop) button (2)
- Press "power" (Netz) button (6)
- Turn key switch (7) counterclockwise -
- Remove mains plug from mains socket.

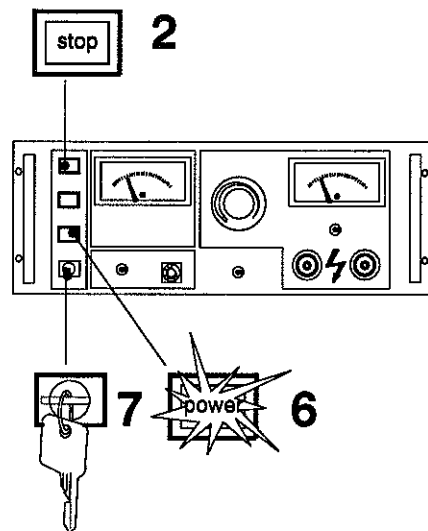

Operating modes (HA 4000A only)

1. "test" (Prüfen)

Permits a non-destructive testing as the high-voltage is switched off by an electronic fuse as soon as a fault current (exceeding of set current limit) occurs.

The response of the fuse causes sounding

- an audible alarm

extinguishing

- the red signal lamp of the "stop" button (2)
- as well as of the red lamp of the external warning lamp set (22) (accessories)

lighting-up

- of the yellow signal lamp of the "power" (Netz) button (6), and
- of the green signal lamp of the "start" (Start) button (1) as well as
- of the green lamp of the external warning lamp set (22) (accessories)

Prepare device again for operation by:

- removing the charge (removal of the test prods) and by
- pressing the "start" button (1).

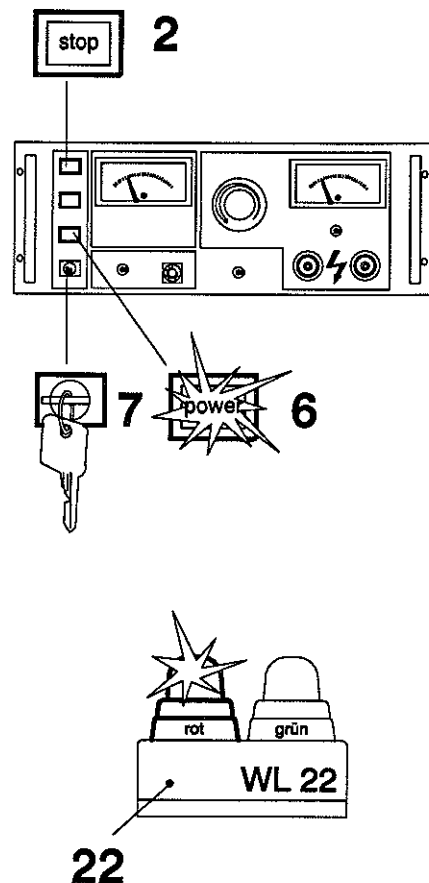

Operating mode (HA 4000A only)

2. "burn" (Brennen)

Caution!
 In the operating mode "burn" the operation time must not exceed 3 minutes.

If a fault has to be localized it is often recommendable to connect high current with high-voltage. The current is limited to max. 200 mA

 The audible alarm and the electronic fuse are switched off during this operation mode. Thereby, a short-time rating of 1 kVA is available.

During testing

- the "current" (Strom) (3) can be observed at the display unit.

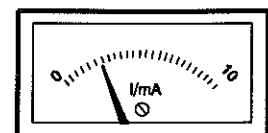
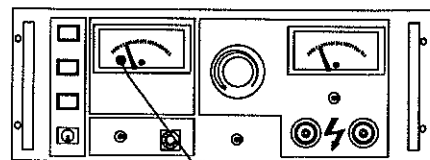

leakage current x10

3

List of Contents Chapter 4

Dimensions, Weight and Rating	4.1
Fuses	4.3
Interface Allocation	
Low-voltage interface	4.4
Warning lamp connection	4.6
High-voltage connectors	4.7

Dimensions, Weight and Rating

 The data in brackets (...) apply to the HA4001A device.

Dimensions:

Width: 464 mm
 Depth: 310 mm
 Height: 177 mm [= 19" / 4 HE]

Weight

Gross: 155 N (140)

Voltage Measurement

HA 4001A: 0 – 5 kV_{eff}
 105 degree scale
 Category 1.5
 potential-free

HA 4000A:
 Range 1: 0 – 2.5 kV_{eff}
 105 degree scale
 Category 1.5
 potential-free

Range 2: 0 – 5 kV_{eff}
 105 degree scale
 Category 1.5
 potential-free

 The measuring range is automatically changed with the voltage range.

Mains Connection

Voltage: 230 V ± 10 %
 Frequency: 50 – 60 cycles
 Rating: max. 1.1 kW
 Fuse: 6.3 A slow blow
Protection class I

Tripping current

HA 4001A: 0 – 0,5 mA_{eff}
 (Safety voltage limited to max. 3 mA)

HA 4000A:
 Range 1: 0 – 10 mA_{eff}
 Range 2: 0 – 100 mA_{eff}
 Burn: max. 200 mA_{eff}

Current Measurement

HA 4001A: 0 – 0.5 mA_{eff}

HA 4000A: 0 – 100 mA_{eff}
 105 degree scale
 Category 1.5
 potential-free

Dimensions, Weight and Rating

Output Voltage

HA 4001A: 0 - 5 kV_{eff}

Distorsion factor: < 5 %

Frequency: 50 - 60 cycles



potential-free to housing and
mains

HA 4000A:

Range 1: 0 - 2.5 kV_{eff}

Range 2: 0 - 5 kV_{eff}

Distorsion factor: < 5 %

Frequency: 50 - 60 cycles



potential-free to housing and
mains

Fuses



Caution! Danger to life!
Remove mains plug before proceeding to open the device.



Data in brackets (...) apply to the HA4001A device.

Device Fuses



correspond to DIN (5x20) and are only blown in case of faulty operation.

Main fuse: 6.3 A (4 As)

External warning lamp red: 1 As

External warning lamp green: 1 As

Electronics: 1 As

All fuses are located on the rear panel of the plug-in board.



In case of breakdown:
 - the high-voltage drops
 - the device cannot be put into operation.

Electronic Fuse

HA 4001A: 0,05 mA_{eff} – 0,5 mA_{eff}

HA 4000A:

Range 1: 1 mA_{eff} – 10 mA_{eff}

Range 2: 10 mA_{eff} – 100 mA_{eff}



infinitely adjustable

Reaction duration: max. 20 ms

Selector Switch

HA 4000A only:

Electric fuse in operation with switch position:

- "test" (Prüfen)

Electric fuse not in operation with switch position:



- "burn" Brennen (limited current!)

Interface Allocation

1. Low-Voltage Interface

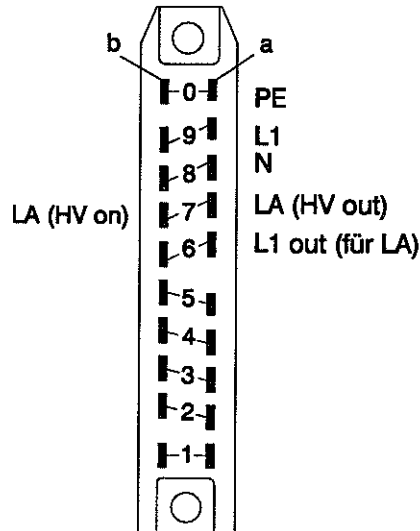
Design as per DIN 41622 (20 poles)
Item 20



Designation	Allocation
PE [a0]	Protective earth-terminal
L1 [a9]	Network phasing (230 V AC ± 10 % max. 4 A)
N [a8]	Zero conductor of supply mains
LA .. (HV out) [a7]	<p>Connection for warning lamps (green).</p> <p> Attention! Network phasing! Danger to life by voltage!</p> <p><u>Technical Data:</u> Voltage: 220 V mains Current: max. 1 A - Fused within device.</p>
L1 out [a6]	<p>Reference potential for warning lamps [LA (HV on) / LA (HV out)]</p> <p> Attention! Network phasing! Danger to life by voltage!</p> <p>At the rear side of the housing (accessory EH 1904-h) you will find a round 4-pole (3 + PE) connector (see page 4.6).</p>

Interface Allocation

Low-Voltage Interface (Cont'd.)

Design as per DIN 41622 (20 poles)

Item 20

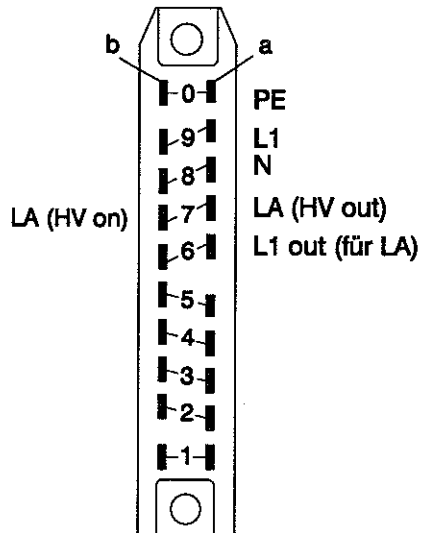

Designation	Allocation
LA . . (HV on) [b7]	<p>Connection for warning lamps (red) - Fused within device.</p> <p> Attention! Network phasing! Danger to life by voltage!</p> <p><u>Technical Data:</u> Voltage: 230 V mains Current: max. 1 A</p>

Interface Allocation

2. Warning lamp connection (in housing - accessory EH 1904-h) Item 19

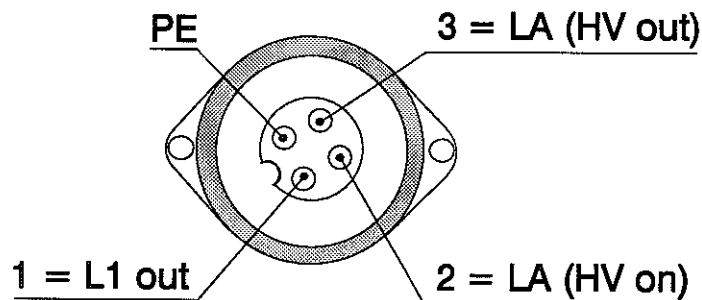

Caution! Danger to life!
The connection is made with mains voltage (230V).

PIN	Designation	Allocation
1	L1 out	Reference potential for warning lamps [LA (HV on) / LA (HV out)]
2	LA (HV on)	Connection for warning lamps (red). <u>Technical Data:</u> Voltage: 230 V mains Current: max. 1 A - Fused within device.
3	LA (HV out)	Connection for warning lamps (green). <u>Technical Data:</u> Voltage: 230 V Netz Current: max. 1 A - Fused within device.
PE	PE	Protective earth-terminal

Interface Allocation

3. High-voltage connectors

For test voltage

Item 14

Item 15

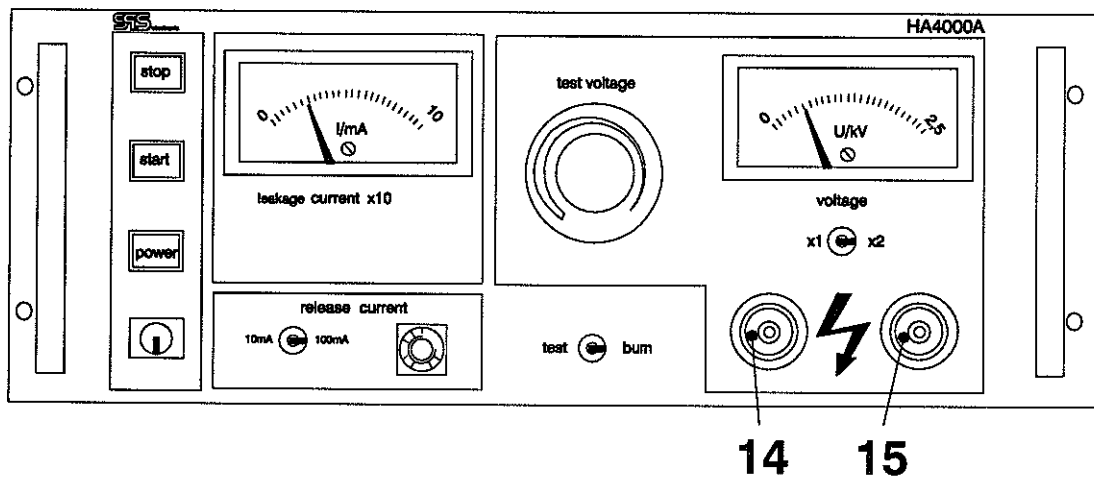

List of Contents Chapter 5

After-Sales Service	5.1
Spare Parts	5.1
HA Series at a Glance	5.4
Accessories	5.4
Important Regulations and Standards	5.5
Terms of Guarantee	5.6

After-Sales Service

SPS electronic
Blätteräcker 18
D-7170 Schwäbisch Hall - Sulzdorf/Germany

Telephone: (07907) 878-0
Service: (07907) 878-25
Telefax: (07907) 1770

Spare Parts

When ordering spare parts, the following information has to be supplied:

- Device designation high-voltage testing device HA4000A or HA 4001A
- Article No.
- Article designation
- Order No. (model)
- Desired quantity

Art. No.	Article	Model	Quantity in device	HA 4000A	HA 4001A
800 190	Plug-in housing	EH 1904-h	–	X	X
890 035	Cable connector plug-in unit	BU 20-n	–	X	X
890 010	Test pistol	SP 02	–	X	X
890 030	High-voltage connector	BU 02	–	X	X
890 011	Warning lamp set	WL 22	–	X	X
890 012	Warning sing	WS 01	–	X	X
890 042	Cable plug for warning lamp	ST 04-r	–	X	X
890 161	BUS board	HA 3000.1	1	X	X
890 162	Current transformer 100 mA	Wdl 60	1	X	
890 163	Current transformer 3 mA/5 kV	Wdl 51	1		X

Spare Parts

Art.No.	Article	Model	Quantity in device	HA 4000A	HA 4001A
850 020	High-voltage transformer 500 VA	HA 50	1	X	
850 021	High-voltage transformer 250 VA	HA 350	1		X
850 000	Variable-ratio transformer 2 A	230 V / 230 V	1	X	
850 002	Variable-ratio transformer 0.8 A	230 V / 230 V	1		X
850 010	Throttle	230V / 230 V	1	X	
840 150	Potentiometer (ceramic)	10k/lin.	1	X	X
840 074	Analog instrument 10 V (DC)	2,5 kV	1	X	
840 075	Analog instrument 10 V (DC)	5 kV	1		X
840 080	Analog instrument 10 V (DC)	0.5 mA	1		X
840 071	Analog instrument 10 V (DC)	10 mA	1	X	
820 090	Resistor	5k6/4W	1	X	X
840 013	Key switch	2xEIN, 1x removable	1	X	X
840 020	Switch	1xEIN Rafi	1	X	X

Spare parts

Art.Nr	Article	Model	Quantity in device	HA 4000A	HA 4001A
840 011	Switch 250 V/4 A	2xUM APR	1	X	X
840 019	Button	1xEIN Rafi	2	X	X
840 018	Bulb	30 V	3	X	X
820 470	Safety fuse 5x20	4At	1		X
820 466	Safety fuse 5x20	1At	3	X	X
820 472	Safety fuse 5x20	6,3At	1	X	

HA Device Series at a Glance

Model	Design	Equipment
HA 4000A	19" / 4 HE	<p>High-voltage testing device with the operating modes:</p> <ul style="list-style-type: none"> - "test" (Prüfen) - "burn" (Brennen) <p>Infinitely variable voltage setting within the range from 2500 VAC to 5000 VAC.</p> <p>Infinitely variable setting of the tripping current within the two ranges 10 mA AC and 100 mA AC.</p> <p>Display units for current and voltage.</p>
HA 4001A	19" / 4 HE	<p>High-voltage testing device with the operating mode:</p> <ul style="list-style-type: none"> - "test" (Prüfen) <p>Infinitely variable voltage setting in the range from 0 VAC to 5000 V AC.</p> <p>Infinitely variable setting of the tripping current within the range from 0.05 mA AC to 0.5 mA AC.</p> <p>Current limit of max. 3 mA for the reason of which no specific protection is required.</p> <p>Display units for current and voltage.</p>

Accessories	
No.	Designation
EH 1904-h	Plug-in housing 19"/4HE
SP 02	Test pistol
WL 22	External warning lamp set
GW 1916	Device carriage
KE 01	PVC chain barrier, by meter
WS 01	Warning sign
AP 01	Guard pillars

Important Regulations and Standards

Regulations for preventing accidents	"General Regulations" (VBG 1)
Regulations for preventing accidents	"Electric Plants and Electrical Equipment" (VBG 4)
Regulations for preventing accidents	"First Aid" (VBG 109)
DIN VDE 0101	"Erection of Power installations with Rated Voltages exceeding 1 kV"
DIN VDE 0104	"Test Equipment with Rated Voltages exceeding 1 kV"
DIN VDE 0105 Teil 1	"Operation of Power Installations General Requirements"
DIN VDE 0106 part 1	"Classification of electrical and electronic equipment protection "against electric shock"
DIN 40 008 part 3	"Safety Signs for Electric Engineering; Warning Signs and Additional Signs"
DIN 40 050	"IP-Degrees of Protection Provided by Enclosures; Protection of Electrical Equipment against Contact Foreign Bodies and Water"

Terms of Guarantee

■ Guarantee Period

12 months from date of shipment.

■ Conditions for a Guarantee Claim

1. The high-voltage testing device HA4000A or HA 4001A must have been put into operation at the customer's plant professionally.
2. Inspections must be carried out regularly (once a year) and thoroughly (by SPS electronic GmbH).
3. Defective or worn parts have to be replaced immediately. The operation of such parts is forbidden for the sake of safety.
4. Defective parts being subject to a guarantee claim have to be sent to SPS electronic GmbH for inspection.
5. Defects occurred must be reported to SPS electronic GmbH without delay.
6. The connecting leads to the high-voltage testing device HA4000A or HA 4001A must have been correctly installed before putting the device into operation (these works are not included in the extent of supply).

■ Beginning of Guarantee Period

The guarantee period starts with the date mentioned on the delivery note.

■ Guarantee

SPS electronic GmbH guarantee a good function of the high-voltage testing device HA4000A or HA 4001A, a conscientious and professional design and manufacture as well as the use of high-quality material.

All parts becoming defective or useless during the guarantee period due to the use of inadequate material, manufacturing faults or an imperfect engineering shall be replaced free of charge.

■ Excluded from the Guarantee are:

1. Damages being due to outside influences, above all because of handling malpractices or of local conditions.
2. Damages at devices from which the serial number has been removed, destroyed or falsified.
3. Wear parts, such as fuses, signal bulbs, etc.