

Operating Manual

Insulation and High Voltage Tester

Series IL3801 / IL3881

Date: 08 May 2017



SPS electronic GmbH
Eugen-Bolz-Straße 8, 74523 Schwäbisch Hall

Phone: +49 791 20 212 - 0
Fax : +49 791 20 212 - 999

e-mail: info@spselectronic.com
Internet: www.spselectronic.com

Table of Contents

1	General Information	7
1.1	Information on this operating manual	7
1.2	Requirements for the operation of this device	9
1.2.1	Regulations for application	9
1.2.2	Product liability	9
1.3	General safety regulations	10
1.3.1	Obligations of the operator	10
1.3.2	Operating instructions for personnel	10
1.3.3	Note on possible disorder of USB devices	11
1.3.4	Information on further publications	11
2	Description	12
2.1	Device functions	12
2.2	Technical data	13
2.3	Set-up of device	15
2.3.1	Front	15
2.3.2	Rear	16
2.4	Scope of delivery	17
3	Putting into operation	18
3.1	Requirements	18
3.2	Connection of device	18
3.3	Initial switching on of device	19
3.3.1	Reconnection of device	19
3.4	Switching off of device	20
3.5	Connection of DUT	20
4	Operation	22
4.1	Explanation of operating elements	22
4.2	Structure of menu	23
4.2.1	Basic structure of screen	23
4.2.2	The main menu	23
4.2.3	Menu "Test Programmes": Outline	24
4.2.4	Menu "Single Test": Outline	25
4.2.5	Menu "System Parameter": Outline	26
4.3	Operation of screen menus	27
4.3.1	Entry of letters and numbers	27
4.3.2	Application of a keyboard	27

5	System menu: Setting of system parameters	30
5.1	General information	30
5.2	Setting of language	30
5.3	Setting of operating mode	30
5.3.1	Operating mode manual	31
5.3.2	Operating mode Digital	32
5.3.3	Operating mode automatic	32
5.3.4	Operating mode Ethernet	32
5.3.5	Operating mode: Barcode	33
5.3.6	Barcode Mask	33
5.4	System time / setting of date	34
5.5	Setting of signal sounds	34
5.5.1	Buzzer	34
5.5.2	Keyclick	34
5.5.3	High Volume	34
5.6	Info	35
5.6.1	Version	35
5.6.2	Info-text	35
5.7	Measurement technique and graphic display	35
5.7.1	Measurement	35
5.7.2	Measuring value display	36
5.8	Setting of password	37
5.9	Setting of interface parameter	38
5.9.1	RS-232	38
5.9.2	Ethernet	39
5.9.3	USB: Copy Files	40
5.9.4	Device ID	41
5.10	Safety - Selection of start control	42
5.11	Printer - Setting of printer format	43
5.11.1	Printer format	43
5.11.2	Headline and footnote	43
5.11.3	Interfaces	43
5.11.4	Printer IP and Printer Port	43
5.12	Maintenance – calibration and service test	43

6	Creation of test programmes	44
6.1	General information.....	44
6.2	Explanation of action menu	44
6.2.1	Load.....	45
6.2.2	New.....	45
6.2.3	Edit.....	45
6.2.4	Cut	45
6.2.5	Copy	45
6.2.6	Insert.....	46
6.2.7	Edit Macros.....	46
6.2.8	Save.....	46
6.2.9	Relocation of a test programme or of a test step	47
6.2.10	Printing of test programme	47
6.2.11	Condition for printer protocolling	47
6.2.12	Program number.....	47
6.2.13	Program model	47
6.3	Editing test programmes and test parameters	48
6.3.1	General information	48
6.3.2	Common parameters and programme settings	49
6.3.3	Continuity test (CT).....	50
6.3.4	Insulation test (I2)	51
6.3.5	High voltage test (H2).....	52
6.3.6	I/O-test	53
6.3.7	Analog I/O.....	55
6.3.8	Text step / visual test	56
6.4	Using macros in test programmes.....	57
6.4.1	Overview.....	57
6.4.2	Creating and editing macros	57
6.4.3	Inserting macros in test programmes.....	58
6.4.4	Editing macros within test programmes	58
7	Performing tests in manual operation	59
7.1	General information.....	59
7.1.1	Preparations ahead of test operation	59
7.2	Program menu during test operation	60
7.2.1	Statistics.....	60
7.2.2	Tester	60
7.2.3	Printing.....	60
7.3	Test programme process.....	61
7.3.1	Outline	61
7.4	Changing of test programme	62
7.5	Statistics.....	62
7.6	Test results and test protocol.....	63
7.6.1	Readout of result on display.....	63
7.6.2	Printer protocolling.....	63

8	External control: operating modes Remote, Digital, Ethernet	64
8.1	Operating mode Remote	64
8.1.1	General information	64
8.1.2	Selection of Remote operation	64
8.1.3	Remote operation escape	64
8.2	Operating mode Digital	65
8.2.1	General information	65
8.2.2	Selection of Digital operation	65
8.2.3	Digital operation escape	65
8.2.4	Digital programme selection	66
8.2.5	I/O-test in digital operation	66
8.3	Operating mode Ethernet	67
8.3.1	General information	67
8.3.2	Selection of Ethernet operation	68
8.3.3	Ethernet operation escape	68
9	Service and function inspection	69
9.1	Service	69
9.2	Function check	69
9.2.1	Dummy test	69
Annex		70
A	Remote Control	70
A-1	General	70
A-2	Syntax description	70
A-3	Globale Commands	71
A-4	Local commands	73
A-5	Status and error parameters	79
B	Interface Configuration	82
B-1	External I/O Interface X6	82
B-2	Serial RS-232 Interface X1	85
B-3	Second external I/O Interface X13	86
B-4	Rear panel connector for test voltages	87
C	LAN Operation – Setup and Procedure	88
C-1	LAN Operation	88
C-2	WLAN Operation	89
D	Description of Test Methods	93
D-1	Continuity Test	93
D-2	Insulation Test	93
D-3	High Voltage Test	93
E	USB devices, and "Testing with High Voltage"	94

1 General Information

1.1 Information on this operating manual

This operating manual is part of the technical documentation for the safety tester *IL 3801* of *SPS electronic GmbH*.

This operating manual contains all the information on how to operate this device properly, safely and economically, how to prevent dangerous situations, how to reduce repair costs and downtimes and how to prolong the service life of these devices.

Should you, while perusing this operating manual, find any misprints, any information you do not understand or which are incorrect please do not hesitate to inform *SPS electronic GmbH* about same.

Structure

This operating manual is divided into nine chapters and one annex.

The annex contains additional information.

The headline shows you which chapter you are reading.

In the middle of the footnote you will find the type of the device and at the end of the line the page number.

Pictographs and Symbols

- **Warnings** are characterized by warning triangles with danger symbol and warn of dangers which can lead to personal injury and/or material damage:



General Warning



Danger caused by electric current or voltage

- **Information** on same are characterized by the Information Pictograph and give advice or additional information:



You can order accessories directly from *SPS electronic GmbH*.

- **Continuations** of contextual paragraphs on the next page are characterized by the symbol  on the right-hand margin.



... *Pictographs and symbols*

Enumerations are characterized by the symbol "•".

Example: • High voltage test (HV test)
 • Insulation test (IS-test)

Operations are divided into consecutively numbered sequences of operations.

Example: 1. Switch on key switch
 2. Push key ON
 3. Turn hand wheel

Results are characterized by the symbol "⇒ "

Example: ⇒ LC-display indicates current programme number.

1.2 Requirements for the operation of this device

1.2.1 Regulations for application

The tester must be in an operational and reliable condition.

Only personnel having completely read and understood this operating manual and who are authorized skilled electricians or who have been instructed in electrical engineering are allowed to perform any operations with and at the testers.

The tester is not to be operated if or for:

- operations are performed which are not specified in this operating manual or which have not been recommended by SPS electronic GmbH concerning installation, operation, maintenance and service.
- unauthorized alterations and/or repairs
- dismantling and/or avoiding of safety devices
- use of components, tools, additional installations, supplements and working material which have not been approved or recommended by SPS electronic GmbH
- building in of spare parts which are not original SPS electronic GmbH spare parts or of spare parts from suppliers not recommended by SPS electronic GmbH

1.2.2 Product liability

The testers have been produced, adjusted and tested according to the state of the art and the approved safety requirements.

The devices comply with the conditions agreed upon by contract of the confirmation of order concerning execution, single parts and accessories selection.

SPS electronic GmbH will be liable for errors or omissions to the extent of the guarantee liabilities of the confirmation of order.

Applicable are the general conditions of delivery of the Central Association of Electrical Engineering and the Electronics Industry, registered association (ZVEI).

The contents of this operating manual is in compliance with the condition of the tester on the date when same was drawn up.

Subject to change are technical alterations because of further developments and improvements of these products by *SPS electronic GmbH*.

Liability claims can therefore not be derived from the contents of this operating manual (data, descriptions, graphs, misprints, etc.).

Errors and omissions excepted!

***SPS electronic GmbH* will only be liable in case of application of the testers according to regulations (pl. see 1.2.1).**

If those regulations have not been applied the operator is solely responsible for risks of hazard to body and life of the user or a third party and impairments of the tester and other material assets!



1.3 General safety regulations

This safety tester IL 3801 has been manufactured according to the state of the art at the time of its delivery.

Nevertheless the tester is not without hazards if it is applied by untrained personnel, applied improperly or not applied according to regulations.



In addition to this operating manual the generally applicable legal regulations and other binding instructions concerning safety regulations, regulations for preventing accidents and regulations for the protection of the environment must be adhered to.

1.3.1 Obligations of the operator

- The tester is only to be operated according to regulations and in operational condition (see chapter 1.2.1)
- Protective and safety devices, locking devices and couplings, etc. have to be inspected by an expert at least once a year.
- A protocol on the test results has to be drawn up in form of a **test report** same has to be retained.
- Instructions on operations with or at a machine or installation as to hazards to health and/or life of persons are obligatory.
- Persons who operate with or at an *IL 3801* have to confirm by their signature to have read and comprehended this operating manual especially in regard to the operating instructions.
- Dangerous zones resulting from the integration of the tester into a system or a device have to be located by the operator and safeguarded against.

When assembling or installing devices, systems or items of equipment of different manufacturers or suppliers and after modifications by company or service personnel where changes within the electric equipment were made the operator has, before putting into operation, to perform a precise inspection according to the accident prevention regulations VBG 4 in compliance with the individually applicable rules of electrical engineering.

1.3.2 Operating instructions for personnel

- Operating instructions, general instructions and regulations are part of the tester and have to be accessible, readable and complete for all those who operate with or at the *IL 3801*.
- Before operating with or at the *IL 3801* questions have to be answered or uncertainties have to be explained by the personnel in charge.
- Any operations with or at the *IL 3801* may only be performed by workers skilled in electrical engineering or trained in electronic engineering and who have been given instructions for such operations and thus been authorized by the operator..
- Testing personnel may only operate the *IL 3801* when a skilled electrician is in charge.
- Adjustments, service and inspections have to be performed according to the instructions specified and according to schedule.

1.3.3 Note on possible disorder of USB devices

When testing with high-voltage, it is possible that failing testpieces may cause disorder of USB devices in close surrounding of the test field.

Please see Annex E for a problem description, and measures to avoid.

1.3.4 Information on further publications

For the protection of persons the trade associations and unions have published below literature:

- DIN EN 50191 Installation and Operation of Electrical Installations
- DIN EN 50274 Protection against Electric Shock –
Protection against unintended direct contact of dangerous active parts
- DIN 40 008 part 3 Safety Signs for Electrical Engineering;
Warning Signs and Additional Signs
- DIN 40 050 IP-Protective System, Protection against Contact, Foreign Matter and Water
for Production Equipment
- DIN 57100 Specifications for the Installation of Power Plants with Nominal Voltages of
up to 1000 V
- BGI 891 Establishing and operation of electrical test plants

2 Description

If not specified otherwise all specifications apply to the device types of series IL 3801 as well as for the respective device type of series IL 3881.

2.1 Device functions

You can perform safety tests at electric devices according to standard test regulations (EN, IEC, VDE etc.) with the safety tester IL 3801.

Below tests can be performed:

	IL 3801F IL 3881F	IL 3881G
Continuity test, 22 V DC with current measurement between the connections L / N	●	●
Insulation test 3000 / 4000 V DC, programmable for measurement of resistance between PE and L + N	up to 3000 V DC	up to 4000 V DC
High voltage test 3000 / 4000 V DC, programmable for checking the electric strength between PE and L + N	up to 3000 V DC	up to 4000 V DC

A description of the test methods is given in the annex.

2.2 Technical data

Measurements and weights			
● width / depth / height	IL 3801F:	ca. 380 / 360 / 150 mm (14" / 3 HU)	
	IL 3881F/G:	ca. 490 / 460 / 180 mm (19" / 4 HU)	
● weight	IL 3801F:	ca. 100 N (10,0 kg)	
	IL 3881F/G:	ca. 120 N (12,0 kg)	
Ambient			
● temperature	operation:	15 °C – 40 °C	
	storage:	5 °C – 60 °C	
● air humidity	max. 70% (uncondensing)		
Connection data			
● power supply	230 V ± 10% / 50 Hz (115 V / 60 Hz optional)		
● power input	max. 700 VA		
Operating data			
● DG-test (continuity test)			
- test voltage	22V DC ± 3%		
- measuring range	up to 500 mA DC (short circuit)		
	range	resolution	accuracy
	0 up to 500 mA	1 mA	1,5% of meas. value ± 1 mA
● I2-test (insulation test)			
- test voltage	IL 3801F : 100 up to 3000 VDC, programmable IL 3881G : 100 up to 4000 VDC, programmable		
- short circuit current	< 10 mA DC		
- measuring ranges	IL3801F : 1500 MΩ max (0.5 MΩ/V) IL3881G : 2000 MΩ max (0.5 MΩ/V)		
	range	resolution	accuracy
IL 3801 F :	0.25 up to 1500 MΩ	meas.display: 0.1 MΩ	Accuracy is a result of the actual ranges for current and voltage, +/- 0.1 MΩ: current: 0.4% meas.range ± 1% actual value range: 200µA, 2mA & 4mA (autorange) voltage: 0.4% meas.range ± 1% actual value range: series F = 3000V; series G = 4000V
IL 3881 G :	0.25 up to 2000 MΩ	min thresh: 0.25 MΩ	
● H2-test (high voltage test)			
- test voltage	IL 3801F : 100 up to 3000 VDC, programmable IL 3801G : 100 up to 4000 VDC, programmable		
- short circuit current	<10 mA DC		
- measuring range	IL 3801F, IL 3881G: 0 up to 4 mA DC		
	range	resolution	accuracy
	200 µA / 2 mA / 4 mA (autorange)	meas.display: 1 µA min/max thresh: 10 µA	0.4% of meas.range ± 1% of readout

● I/O test	
- Inputs 1 – 8	Input voltage: 20 V DC – 28 V DC Input resistance: 4.7 kOhm
- Outputs 1 – 8	Output voltage: corresponding to input voltage applied to PIN 20 and 21, 10 – 28 V DC Output current: max. 200 mA per output potential free to test voltage and internal supply, short-circuit proof
● Accuracy and tolerance (HV and IS Test, for IL 3801 F, IL 3881 G)	
- output voltage	reproducibility between 100V and 3000/4000V: ± 2% of nominal value
- voltage display	above 100V: 0.4% of max. value ± 1% of actual value
- current display	0.4% of max. value ± 1% of actual value
Features	
<ul style="list-style-type: none"> ● IL3801F: 14" / 3 HU (housing), with integrated LC-colour display IL3881F/G: 19" / 4 HU (plug-in), with integrated LC-colour display ● RS-232 – interface for printer connection or remote control ● menu-driven test programme creation 	

2.3 Set-up of device

2.3.1 Front

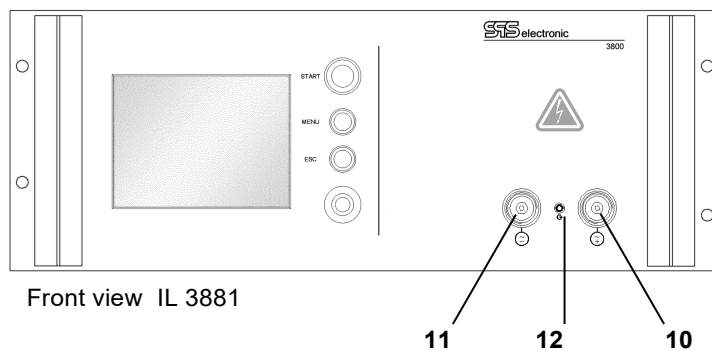
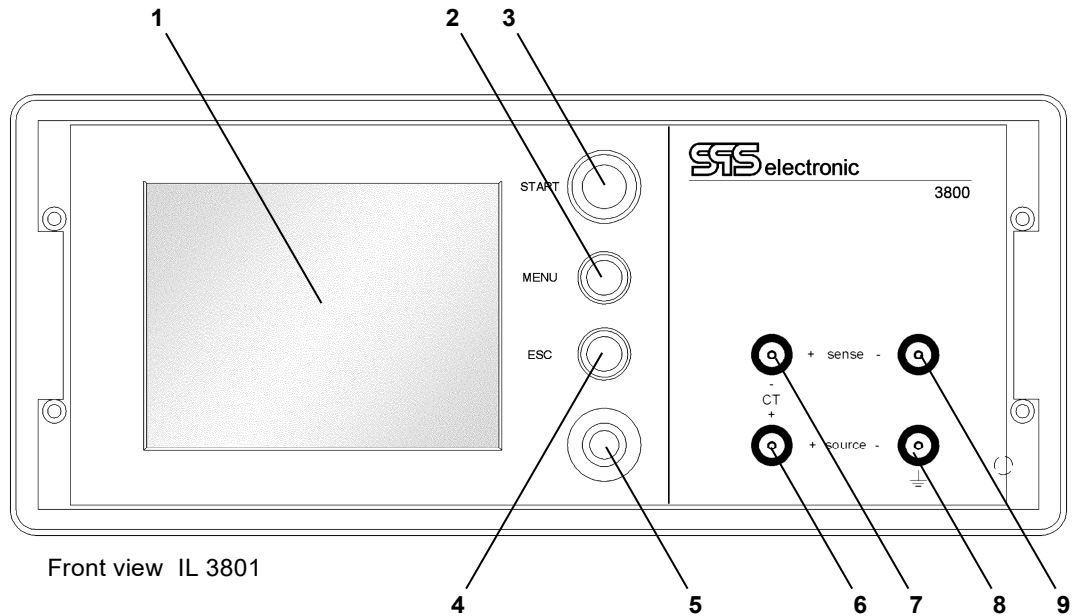

- 1 LC colour display
- 2 operating key "MENU" – *calls Quick-Menu*
- 3 operating key "START" – *starts test*
- 4 operating key "ESC" – *escape from an action, change into the superior menu*
- 5 operating element: navigation wheel and key – *navigation in menus, changing of parameters*

Only for series 3801:

- 6 terminal: test voltage pos.
- 7 terminal: sense voltage pos.
- 8 terminal: test voltage neg.
- 9 terminal: sense voltage neg.

Only for series 3881:

- 10,11 terminals for connection of high voltage pistols (10: pos. / 11: neg.)
- 12 socket for signal line (for high voltage pistols with integrated start key)

2.3.2 Rear

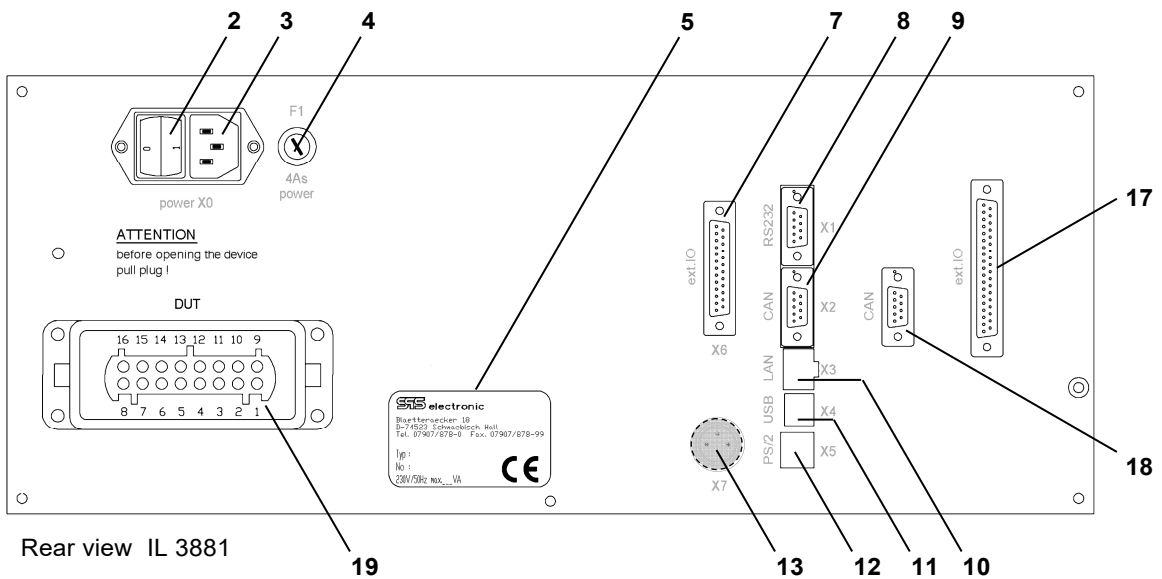
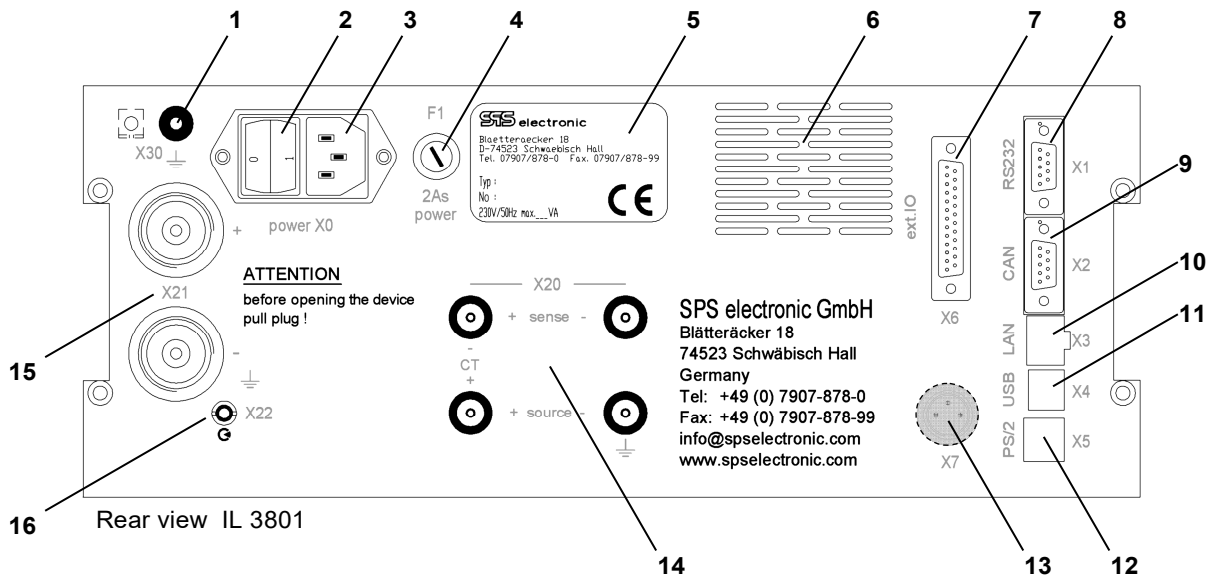

Legend

- 1 earth connection (X30) ¹⁾
- 2 power switch for switching device on and off
- 3 cold equipment socket for power supply cable (X0)
- 4 main fuse (F1) (2A, slow-acting)
- 5 type label with
 - address of manufacturer
 - name of device (type)
 - serial number (no.)
 - max. power input at 230 V / 50 Hz in VA
 - CE mark
- 6 ventilation grid – keep absolutely free of obstruction! ¹⁾
- 7 I/O interface (X6)
- 8 RS232 interface (X1) : serial interface for connection of printer or PC
- 9 CAN interface (X2) : CAN-bus for device extensions
- 10 LAN connection (X3) : Ethernet-connection (10BaseT)
- 11 USB-A connection (X4) : interface for connection of PC (USB 1.1)
- 12 USB-B connection (X5) : interface for connection of keyboard or barcode readers
- 13 analogue output (X7) : (optional device equipment)
- 14 terminals for test and sense voltages (X20) ¹⁾ (same allocation as front terminals)
- 15 terminals for connection of high voltage pistols (X21) ¹⁾
- 16 socket for signal line (X22) ¹⁾ (for high voltage pistols with integrated start key)
- 17 I/O interface²⁾ : additional interface, in connection with (18)
- 18 CAN interface²⁾ : is coupled to (9) to control (17)
- 19 industrial plug and socket connection³⁾ : interface for test adapter or external test voltage supply

¹⁾ only for series 3801

²⁾ only for series 3881

³⁾ only for series 3881 / with system extension RA 3880

2.4 Scope of delivery

Included are below standard accessories for this device. If required these accessories can, of course, also be ordered separately.

- power cable
- interface cable RS-232
- operating manual of the device (i.e. this document)

3 Putting into operation

3.1 Requirements



Tester *IL 3801* as well as all of the electric connections and lines must be in operational and reliable condition.

Tester may only be operated by an authorized and skilled electrician or someone with such training and who is in charge at the time.

The General Safety Regulations (pl. see chapter 1.3) and the generally applicable legal rules as well as other binding directives for industrial safety, for accident prevention and for the protection of the environment have to be adhered to and persons staying in the area of operation must be informed respectively.



There is danger to life caused by electric current or voltage in case of handling electric installations inappropriately!

3.2 Connection of device

1. switch off, if necessary, power switch at tester
2. plug power cable of tester into cold equipment socket (X0) at back of device
3. connect power cable to power supply (230 V / 50 Hz, other values optional)
4. connect measuring lines to sockets at the front panel (Pos.6-9) or at the rear panel (X20)
5. If provided for, connect external devices to the destined interfaces.

3.3 Initial switching on of device

The IL 3801 is switched on via the power switch at the back of the device (Pos.2).

The test device then is starting its internal Operating System. This takes approx. 25 seconds. When finished, the device is showing the main menu (see p. 23), resp. the screen of the operating mode that has been active at last.

3.3.1 Reconnection of device

After switching on device is again in the operating mode in which it was when last switched off:

State when switching off	State after switching on again
operating mode "Manual"	Loaded is the test programme which was active last. If no test programmes have yet been created the IL 3801 will display the menu selection message.
operating mode "Remote"	After the automatic test the device returns to the remote mode and awaits instructions via the active remote interface X1 or X6. (escape with key "ESC")
operating mode "Digital"	After the automatic test the device immediately returns into digital operation and awaits signals on X6 (ext. I/O). (escape with key "ESC")
operating mode "Link"	As in "Manual" the programme which was loaded last will be loaded anew. However, the operating mode "Link" is still active.
operating mode "Ethernet"	After the automatic test the device immediately returns into the Ethernet operation and awaits signals on X3 (LAN). (escape with key "ESC")

3.4 Switching off of device

The safety tester IL 3801 is switched off by means of the power switch at the back of the device.
 If you operate in the menu "Test Programmes" to create new programmes or to alter existing ones then all of the alterations must be stored before switching off! (pl. see chapter 6.2.8)



In case of tests with high voltage (IS- and HV-test) the DUT has to remain connected until a test result is displayed. At the end of the test time the DUT is discharged. If the IL 3801 is switched off prematurely the DUT cannot be discharged!

3.5 Connection of DUT

IL3801: Connection scheme for 2-wire operation:

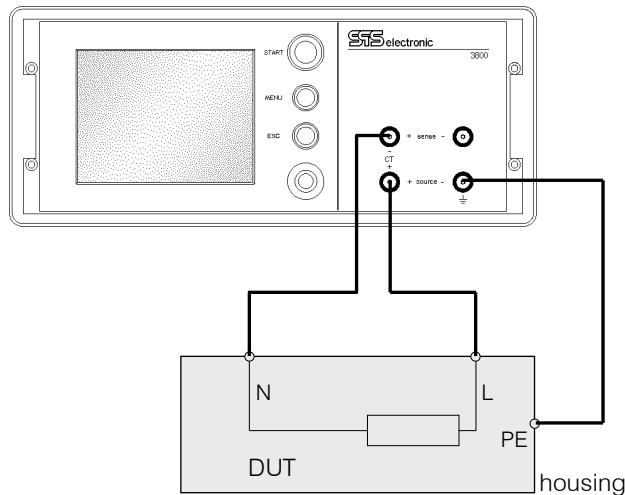

IL3801: Connection scheme for 4-wire operation:

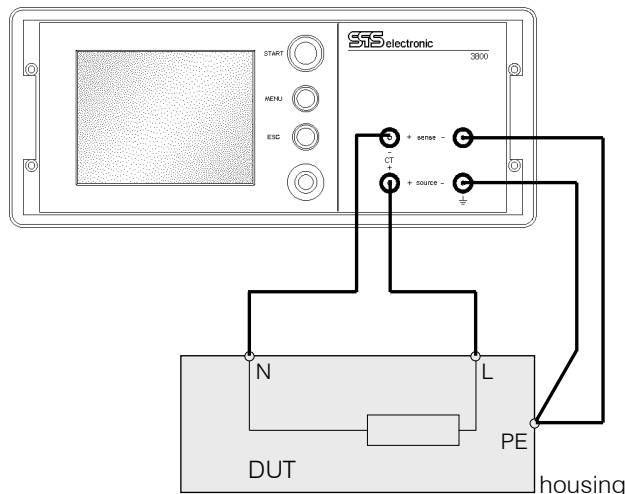

Connection of DUT using rear panel interface:

IL3881: Connection scheme for 2-wire operation:

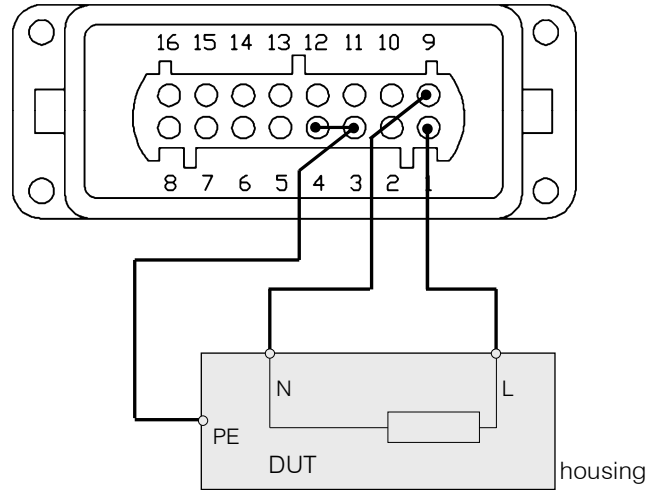

IL3881: Connection scheme for 4-wire operation:

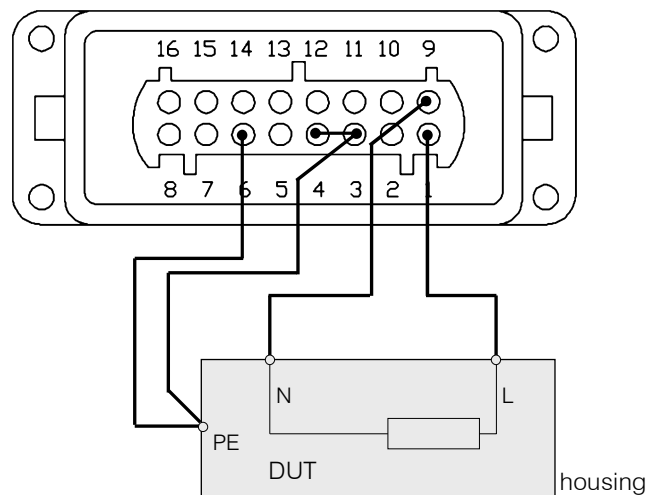

4 Operation

4.1 Explanation of operating elements

The safety tester IL 3801 is operated most simply by means of the operating elements at the front of the device.

The central element is the handwheel with which almost all operations are performed. The handwheel cannot only be *turned*, but also be *pushed* to actuate an operation.

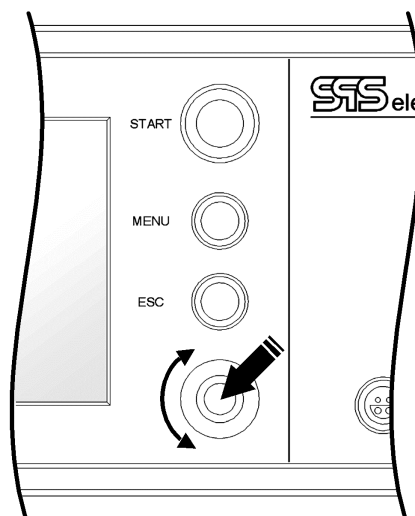

Operating element	Function
key START	Starts a test programme or a single test
key MENU	Displays a quick-menu in the status line to allow quick access to important functions
key ESC	Escapes from current operation – e.g. a current test, input of a parameter, etc. Serves also for a quick change into the superior menu
handwheel	With the handwheel movements through the various screen menus, input of parameters and the actuation of operations are performed

4.2 Structure of menu

4.2.1 Basic structure of screen

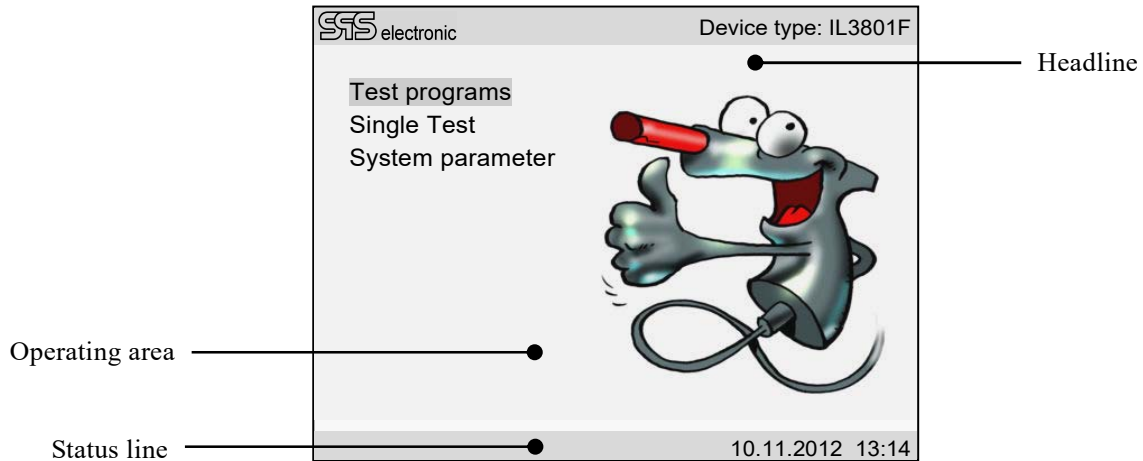

- The *headline* displays the exact type and the variant of the DUT.
- The *status line* shows the time and the current date as a standard. "Quick-Menu" can be displayed in this line in test mode.
- All of the other operations are carried out in *operating area*: creation of programmes, test operation and display of results, etc.

4.2.2 The main menu

All of the functions of the IL 3801 can be reached via the main menu and, if necessary, be altered.

The main menu offers access to below three groups:

- **Test programs** This is the central menu of the IL 3801:
 - From here regular test operation are performed with test programmes created previously.
 - Here test programmes can be created, altered and administered. Each test programme can consist of any sequence of single tests and can be provided with a specific name.
- **Single test** Single tests can be performed directly via this menu without having to first programme a test programme. This function is especially suited for the setting-up operation, or e.g. for special tests, as single tests with varying parameters can be performed especially quickly and easily.
- **System parameter** Here all system parameters of the IL 3801 can be adapted: Language of operating surface, operating mode of device, parameter of external interface, passwords, etc.

4.2.3 Menu "Test Programmes": Outline

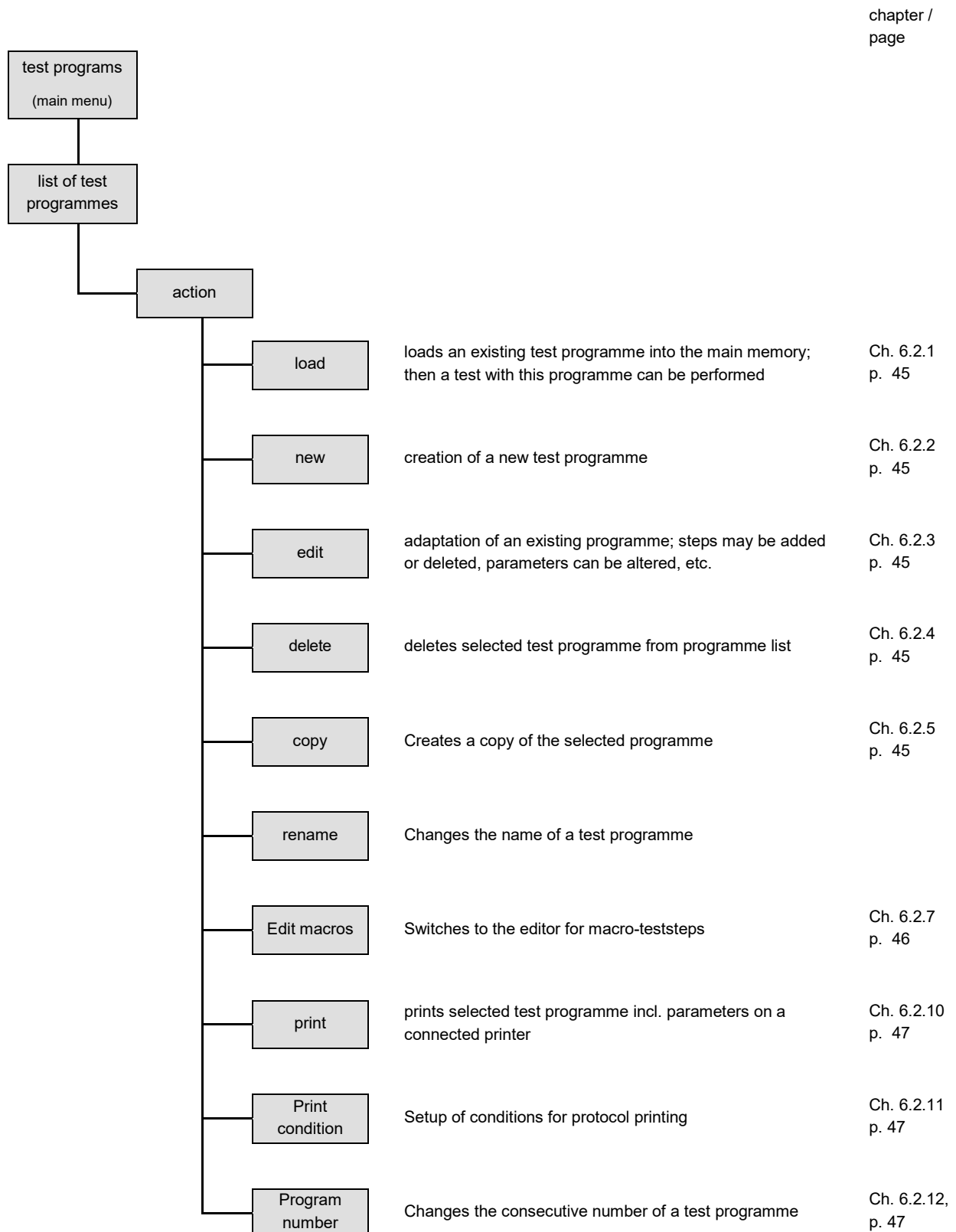

4.2.4 Menu "Single Test": Outline

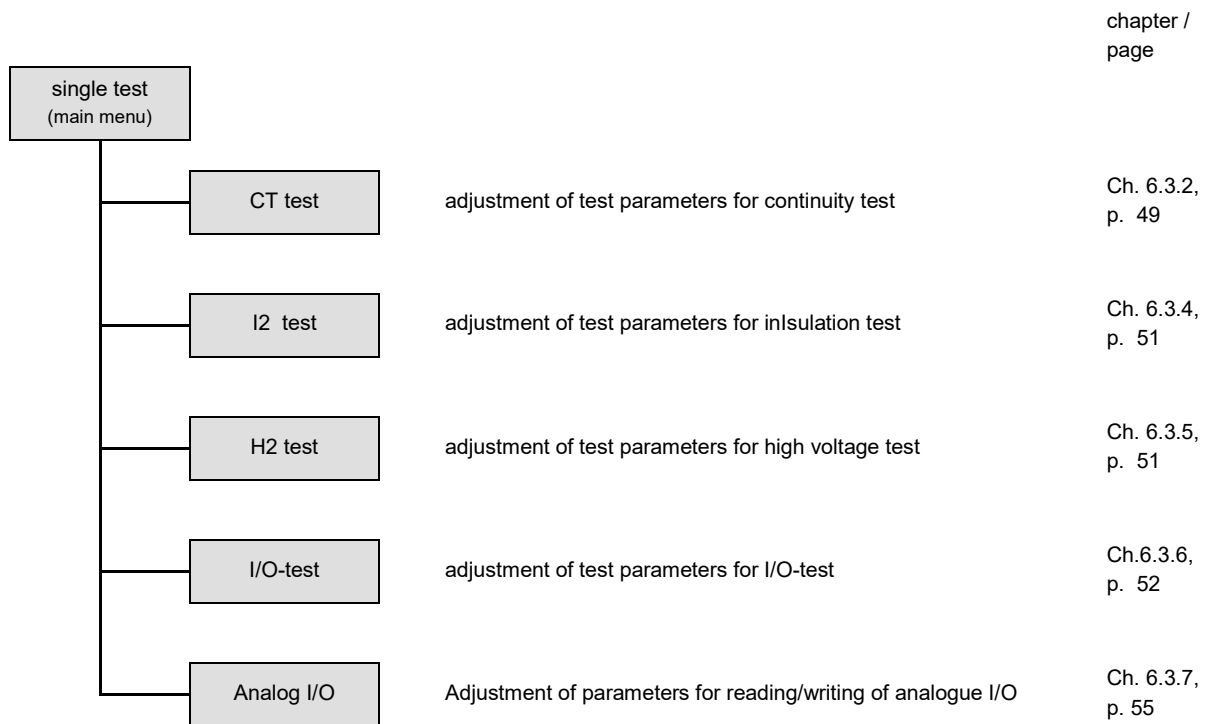

4.2.5 Menu "System Parameter": Outline

			chapter / page
system parameter (main menu)			
language	<ul style="list-style-type: none"> • German • English • French 	<ul style="list-style-type: none"> • Italian • Spanish • Dutch 	ch. 5.2, p. 30
operating mode	<ul style="list-style-type: none"> • manual • digital • automatic 	<ul style="list-style-type: none"> • Ethernet • Barcode • Barcodemask 	ch. 5.3, p. 30
system time / date	<ul style="list-style-type: none"> • date • time 		ch. 5.4, p. 34
signal sounds	<ul style="list-style-type: none"> • buzzer – (off / silent) • keyclick – (off / on) • high volume – (off / on) 		ch. 5.5, p. 34
info	<ul style="list-style-type: none"> • version: firmware-version and device type • infotext: you can select any information text 		ch. 5.6, p. 35
measurement	<ul style="list-style-type: none"> • measurement display • statistic • 4-wire measurement 		ch. 5.7, p. 35
password	<ul style="list-style-type: none"> • program password • menu password 	<ul style="list-style-type: none"> • service password • macro password 	ch. 5.8, p. 37
interfaces	<ul style="list-style-type: none"> • RS-232 • Ethernet • USB 	<ul style="list-style-type: none"> • Device ID 	ch. 5.9, p. 38
safety	<ul style="list-style-type: none"> • start key • probe • Other input 	<ul style="list-style-type: none"> • Use for start • Check after step 	ch. 5.10, p. 42
printer	<ul style="list-style-type: none"> • print format (narrow / page / endless / line) • headline (<i>any text</i>) / footnote (<i>any text</i>) • Interfaces • serial number (no / yes / upward) 		ch. 5.11, p. 43
service	<ul style="list-style-type: none"> • calibration • service 		ch. 5.12, p. 43

4.3 Operation of screen menus

All screen menus contain different elements of which one each has a yellow background and same is the currently active element. By *turning* the handwheel you go to the next or previous element respectively. The selected element is activated by pushing the navigation wheel.

4.3.1 Entry of letters and numbers

For several actions the user has to enter numbers and/or letters, e.g. when assigning a name for a test programme or when entering the password.

Below screen mask is displayed then:

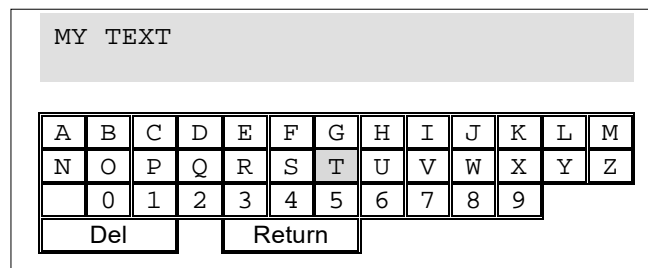

In the lower part of the mask all characters which are available for entry are displayed.

Above same the entered text is displayed. Unassigned areas are displayed by the character "_".

By turning the wheel the requested character is selected and entered by pushing the wheel. If characters are to be deleted the symbol "Del" has to be selected and activated.

To end a text entry the symbol "Return" has to be selected and activated.

By using the key ESC, the dialog is quit and the entered text is discarded.

4.3.2 Application of a keyboard

To further facilitate the operation a standard PC-keyboard (PS/2) can be connected to the USB port X5 at the rear panel of device IL 3801.

The application of a keyboard is especially useful then when texts are to be entered frequently like e.g. commentaries on test performance or serial numbers of DUTs.

Keyboard functions

Key(s)	Function	Corresponds to
A...Z and 1...0	with these keys letters and numbers can be entered directly	—
Cursorblock (← ↑ ↓ →)	with same the selection mark is moved within a screen	turning of handwheel
ENTER (↵)	selection of elements of display mask	pushing of handwheel
ESCAPE (Esc)	escape from an action	ESC-key

Application example:

In this example, proceeding from the main menu, below steps are carried out:

Change into system parameter menu, alteration of system language from German into English, return to main menu

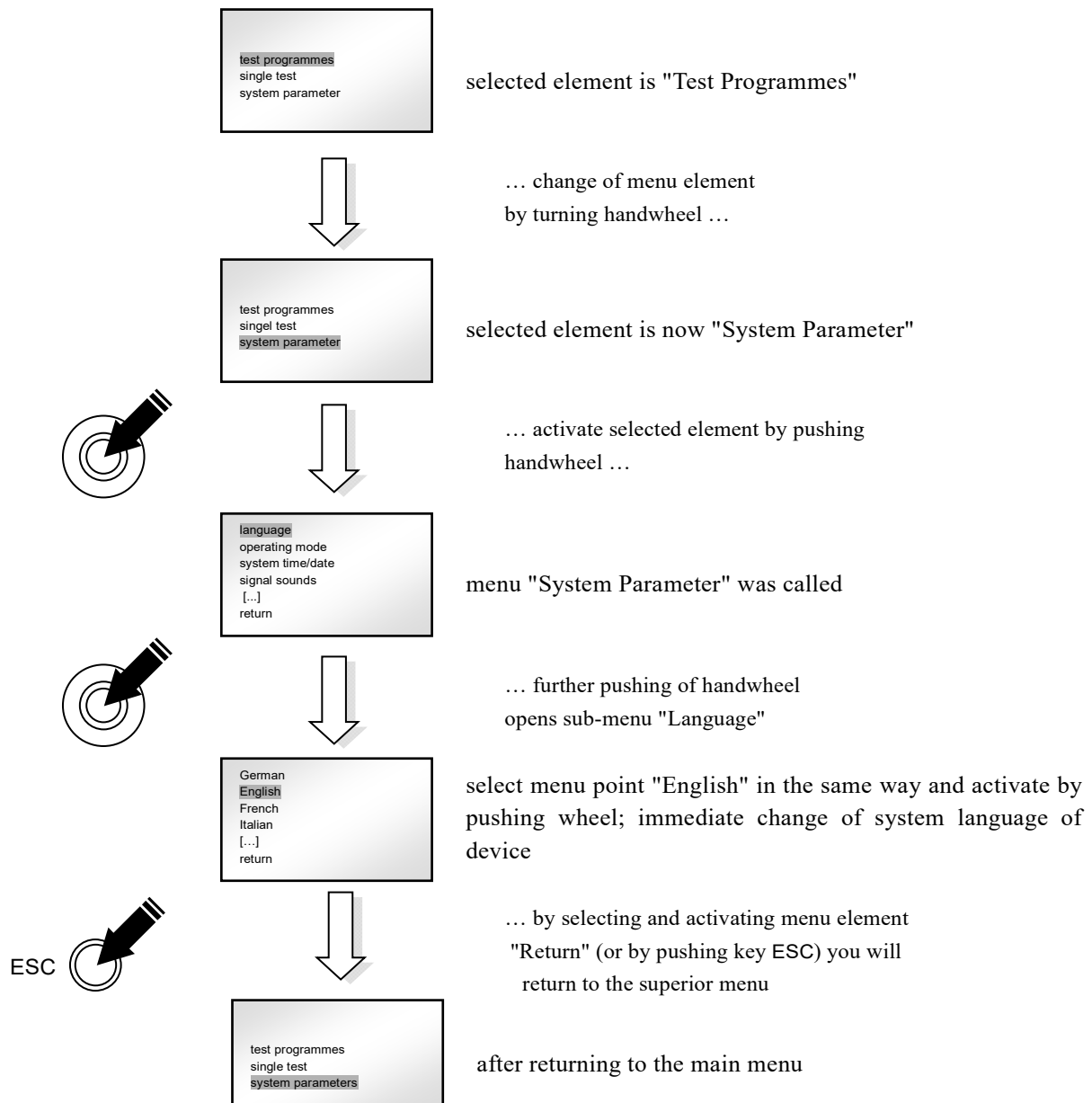

Application example:

In this example below steps are carried out:

Change into single test menu, selection of continuity test (DG), alteration of limiting values from absolute to relative measurement, return to main menu

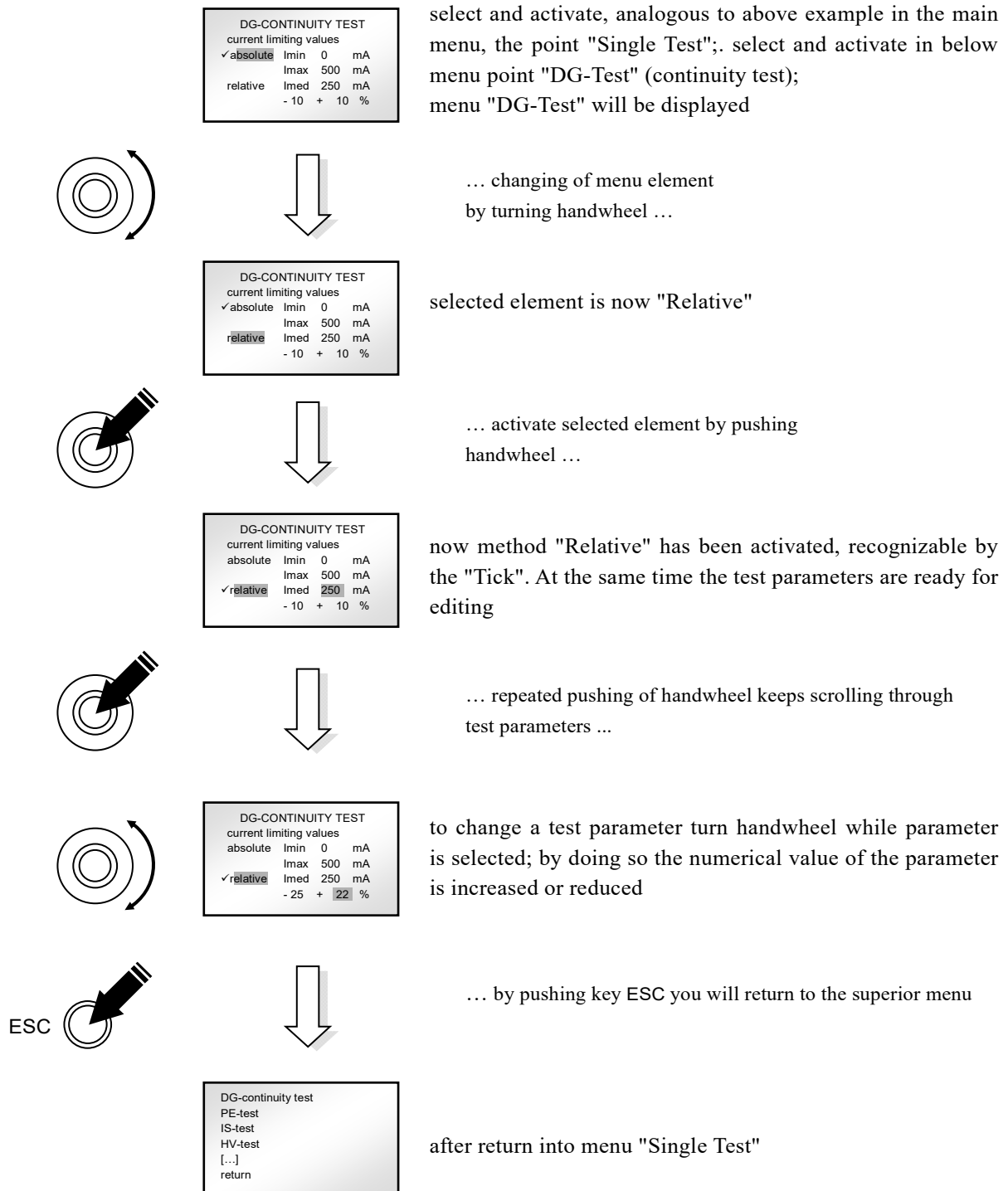

5 System menu: Setting of system parameters

5.1 General information

In the area of system parameters important basic settings on all functions of the IL 3801 are defined.

On below pages you will find explanations on the options of all system parameters.



To guarantee a correct and safe test operation, the "System Parameter" area should be made absolutely inaccessible by password to unauthorized persons.
Please observe the information on the application of the password in chapter 5.8, p.37.

5.2 Setting of language

With this parameter you can change the system language of the **operating panel**.

After having selected a language with the handwheel all screen dialogues when acknowledged by means of pressure on the hand wheel will be switched immediately to the new language.

The available languages are:

- **German**
- **English**
- **French**
- **Italian**
- **Spanish**
- **Dutch**

5.3 Setting of operating mode

With same you can switch over between the different operating modes of the device:

- **Manual** Regular, manual test operation with single tests or with test programmes
- **Automatic** In automatic operation the tester is remote-controlled by a connected PC via interface X1 (RS-232), X3 (Ethernet) or X4 (USB). (Pl. see chapter 8.1, p. 64.)
- **Digital** Test programme selection and start/stop functions are performed in digital test operation via digital interface X6 ("ext. I/O"). (pl. see chapter 8.2, p. 65.)
- **Ethernet** In Ethernet operation device is integrated into a local network (LAN) and the test programmes and results are administered by a central server.
(Pl. see chapter 8.3, p. 67.)
- **Barcode** In this operating mode a product barcode is read in, then the required test program is loaded and started.
- **Barcode mask** The barcode mask defines how a read barcode is to be evaluated

5.3.1 Operating mode manual

If you select mode *Manual* as operating mode then a dialogue screen will appear on which further options for this operating mode can be defined:

- **Digital output** If "Digital Output" is **activated** (default option), then outputs 1–4 of the I/O-interface are used for hardware status signals. For test step "I/O-Test" only outputs 5–8 (and all of the inputs) will be available then.

If "Digital Output" is not **activated** , then all 8 inputs and all 8 outputs of digital I/O-interface **X6** are available for test step "I/O-Test".

(pl. see also chapter 0, p. 52, and annex B-1)

Save results: This setting controls if and how the device will save the test results.

- **save no results** In case of "save no results" the device will only memorize the results of the latest test run. As soon as a new test run is started, the results of the preceding test can't be recalled anymore (except indirectly, by means of the test statistics which gets actualized with all PASS and FAIL results).
- **save results to USB** With "safe to USB" the result of each completed test run is saved to a mass storage device (e.g. USB stick) connected to interface X5.

Hint: The default setting is "save no results".

Saving of test results may become useful especially when the device is used in network operation. In case that the connection to the database server is interrupted (e.g. network failure), testing can be continued nonetheless, without losing any of the test results. The results achieved in the time during network failure can be exported from the device at some later time, then the database can be updated.

- **Serial number** Here the settings of the serial number function for the printer protocolling are carried out. Serial numbers can consist of 1-digit to 10-digit numbers, they can only consist of figures (no letters).

- **No** There are no serial numbers in the protocol.

- **Yes** Before each test the entry of a serial number is requested.

- **Upcounting** With each test start, the serial number is automatically increased by "1".

After having selected "upcounting" a display appears into which the requested start serial number can be entered.

- **Set Ser.Nr.** If needed, the serial number for the next test can be set manually.

5.3.2 Operating mode Digital

After having selected operating mode "*Digital*" a dialogue screen will appear with further options for this operating mode:

- **Activate** If an other operating mode than "Digital" was se tbefore then this option has to be selected to activate operating mode "Digital".
- **Acknowledgement** With this option you can set how to perform an ERROR test in digital operation. If "Acknowledgement" has **not** been activated the next test will be immediately started by a start signal EXT_START on X6.
If "Acknowledgement" has been **activated** then an erroneous test has to be acknowledged first via EXT_ACK before the next test can be started via EXT_START.

Information:

If "Acknowledgement" for the digital mode is activated then the acknowledgement of an ERROR test result will also be requested in the manual test mode.

5.3.3 Operating mode automatic

After selecting operating mode automatic a menu will be displayed in which the interface applicable for automatic operation can be selected (RS-232, USB, or Ethernet).

After selection of the menu item "Activate" IL 3801 switches to automatic operation and is waiting for commands via selected interface.

(pl. see chapter 8.1, p. 64)

5.3.4 Operating mode Ethernet

There are no further options to operating mode Ethernet. After selection of this option and activation of menu "Activate" the IL 3801 switches immediately into network operation and is waiting for a product barcode to be read in. (pl. see 8.3, p. 67)



Before applying operating mode "Ethernet" the Ethernet parameters (pl. see 5.9.2, p. 39) have to be adapted to the conditions of the local network. If these parameters have not been configured correctly, communication between tester and the central server cannot be effected!

5.3.5 Operating mode: Barcode

This option switches the device to the (manual) barcode operating mode.

The device is now waiting for the entry of a barcode. When a barcode is received, the device will figure the required test program from the barcode data (acc. to "barcode mask" settings, see below), load the test program into memory, and execute it.

Entry of a DUT's barcode

Entry of a barcode can be done in the following ways:

- By a barcode reader (connected via USB)
- Manual entry via keyboard (USB)
- Manual entry via onscreen-keyboard

5.3.6 Barcode Mask

To use the operating mode "barcode", a "barcode mask" has to be defined in this menu. The barcode mask determines how the barcode data will be interpreted.

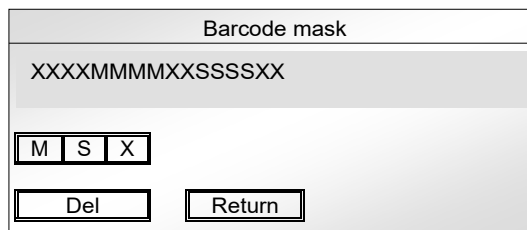

The mask can contain the positions "M", "S" and "X" :

M = "Model". These characters are used to select the required test program.

S = "Serial Nr.". These characters are used to build the DUT's serial number.

X = other character. To be used for positions that are neither model nor serial number.

Important: The barcode mask must have exactly the same length (count of characters) as the barcode that is read during testing operation. If the barcode contains less or more characters than the barcode mask, the test run will be halted with error "barcode too short / too long".

Example:

	Year / month				Model number				Color		Serial number				other tokens	
Product barcode:	0	8	0	5	6	5	8	7	0	4	0	8	1	5	9	9
Barcod mask:	X	X	X	X	M	M	M	M	X	X	S	S	S	S	X	X

Assignment of test programs:

Upon creation of a test program, the menu entry "program model" is used to enter a barcode containing the required unique model number. (see also Chpt.6.2.13, p.47)

When a barcode is scanned during test operation, the device looks up for the first testprogram for which the "M"-positions of the code in "program model" are identical to the "M"-positions of the scanned barcode. This program then is loaded and started.

5.4 System time / setting of date

If required system date and system time of device can be set here.

5.5 Setting of signal sounds

5.5.1 Buzzer

With this parameter you can set the signal sound of your device which will sound at the end of the test if the test result is ERROR.

Below settings are available:

- **Off** The buzzer is de-activated, no signal will sound at the end of the test.
- **On** After an ERROR test a warning signal will sound

5.5.2 Keyclick

As feedback a signal will sound regularly with each push on the handwheel. This signal sound can be turned on or off as required.

Available parameters:

- **Off** No acknowledgement sound when pushing key at device
- **On** Each push of the key will be acknowledged with a signal sound

5.5.3 High Volume

This option increases the volume of all signal sounds, e.g. when operating in an environment with high ambient noise level.

5.6 Info

5.6.1 Version

For your information below device data will be displayed:

- revision number of firmware of device
- type of device and – its variant / version
- date on which device should be calibrated next

5.6.2 Info-text

A general info-text can be entered here. When switching on the device this text will be displayed during the initializing phase and can be opened by selecting this menu during the operation in process.

This function can e.g. be used to identify different devices which were programmed with different setups.

This info-text can maximally consist of 30 characters.

For input of this information text please see information on page 27.

5.7 Measurement technique and graphic display

5.7.1 Measurement

In this parameter group, settings regarding voltage measurement and voltage ramp can be changed.

These settings are related to insulation and high voltage testing only.

Available parameters in "wire" group:

- **2-wire** Conventional measuring technique, with voltage supply by two lines. Here, voltage drops proportional to line length must be taken into account.
- **4-wire** Measurement during HV-tests (H2) are performed using 4-wire-technique, i.e. two lines are current-carrying (source), and the two other lines are used for currentless voltage measurement (sense).

This setting does not apply to Insulation Test (I2): this one is always performed in 2-wire-technique. (See note p. 51)

Available parameters in "ramp" group:

- **Ramp on** When testing with high voltage, the test voltage is applied "smooth" by means of a voltage ramp. At a test's end, voltage ramp is used, too.
- **Ramp off** Voltage ramping is not used. Full test voltage is switched on and off directly.

5.7.2 Measuring value display

In this menu you can select how to display the measuring values established during a test on the colour display.

The available display methods are:

- **Off**

With this setting the measuring values of the test are not displayed. There will only be the evaluation PASS/FAIL after the end of the test process.

- **Digital**

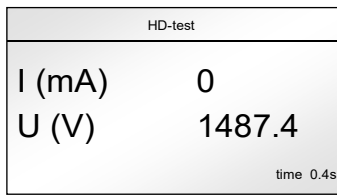

Measuring values are only displayed numerically.

- **Bargraph**

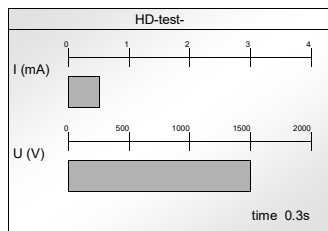

Measuring values are displayed as horizontal bargraph.

- **Needle**

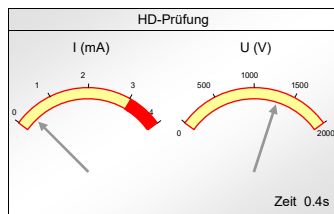

Measuring value display is modelled on analogue circular instruments.

- **X/Y**

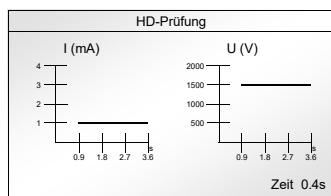

This measuring value display is shown in a line graph in a Cartesian dot-frequency diagramme in which the measuring values are plotted via the time.

5.8 Setting of password

Via the password setting access to the different functions of the device can be limited.

Available parameters:

- **Program password** With same, the possibility to alter existing test programmes can be limited. The input of the programme password is essential to edit existing programmes or to create new programmes. Without knowledge of the programme password you can only test with the currently existent programmes.
- **Menu password** With same, access to the menu "System Parameter" can be protected. Without knowledge of the menu password there is no access to the "System Parameter" and any alterations there will not be possible.
- **Service password** With this password the service area of the device is protected. The service area should only be used by SPS electronic GmbH technicians or with their instructions!
- **Macro password** With this password the macro editor of the device is protected.

The input of the password is carried out as explained in "Input of Characters" on page 27.

If a password is to be reassigned the current password has to be entered first – for confirmation of authority – before assigning the new one. Without knowledge of the current password an alteration will not be possible.

It will be possible to annul the respective password function by assigning a "blank" password. In this case there will be no password query in the respective area until a new password has been assigned.

The passwords can consist of up to 15 characters.

Attention:

Once after an area has been accessed by entering the correct password this area will be accessible **until the device is switched off and then switched on again!**

This means that if e.g. a person in charge alters the system parameter during a test operation (for which the menu password has to be entered) then the device should under any circumstances be switched off after the alteration has been carried out and then it should be switched on again! If not then the area "System Parameter" were to remain accessible and unauthorized alterations would be possible.

On delivery the programme and menu password are not activated.

After putting into operation of the device the passwords should be reassigned to avoid unauthorized operation.



5.9 Setting of interface parameter

In this menu the operating parameters of the rear interfaces for the remote operation can be set:

- **RS-232** Switches to the sub-menu for the RS-232 interface
- **CAN** Switches to the sub-menu for the CAN interface
- **Ethernet** Switches to the sub-menu for the ethernet interface
- **USB** Switches to the sub-menu for the USB interface
- **Device ID** Assignment of a device appellation for identification in the network (max. 15 chars)

5.9.1 RS-232

- **Baud rate** Sets the data transfer rate in symbols/second (4800/**9600**/19200/57600/115200)
- **Data bits** Sets the number of data bits per data word (5/6/7/**8**)
- **Stop bits** Sets the number of stop bits per data word (**1**/2)
- **Parity** Sets the parity bit for error control (even / odd / **none**)

Default values: 9600 / 8 / 1 / none

5.9.2 Ethernet

The ethernet interface primarily is used to integrate the tester into a network. However, "remote control" operation can be performed using this interface, too.

- **IP address** "Address" of tester in the network, format "xxx.xxx.xxx.xxx". This IP has to be assigned to each tester locally and has to be non-recurrent in the network.
- **Subnet mask** When applying sub networks, this mask determines which parts of the IP-address contain the network-ID (identification: "255") and which contain the host-ID (identification: "0"). (default: 255.255.255.0)
- **Gateway** If there are more than one network connected in the local Ethernet via a gateway then the IP of the gateway must be entered here (format "xxx.xxx.xxx.xxx")
- **Printer IP** "Address" of a network printer, format "xxx.xxx.xxx.xxx".
- **Printer port** Sets the "channel" to use for communication with the network printer.
- **Server IP** "Address" of central server, format "xxx.xxx.xxx.xxx".
- **Server port** Sets the "channel" to use for communication with the server.
- **Timeout** Maximum period of time in seconds (after the device has transmitted a barcode to the server), within which an answer from the server has to be received before an ERROR message can be displayed and the contact trial is cancelled.
- **Light** When selecting option "Light" the test operation is performed with the locally stored programmes of the tester, the server will only receive the results.
If not then the test operation is performed with the programmes stored on the server which are loaded into the tester at the beginning of the test via the network.
- **Barcode** When enabled, the server may only send a test program to the testing device when a barcode has been read in at the device, and the barcode was sent to the server.
When disabled, the server may send a test program to the device at any time.
- **MAC address** The MAC hardware ID of the network card. Same is printed on bottom of the card – must not be changed without a specific reason.

5.9.3 USB: Copy Files

With this function it is possible to copy the various data files from the tester to an USB mass storage device, or from an USB device into the tester:

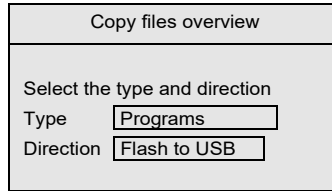

<ul style="list-style-type: none"> • Type <ul style="list-style-type: none"> ○ Programs ○ Macros ○ Results (Flash) ○ Results (Ramdisk) ○ Configuration ○ Device 	<p>Selects which kind of files are to be copied:</p> <ul style="list-style-type: none"> Copies one or all test programs (format *.xml) Copies one or all macro steps (format *.xml) Copies saved test results between Flash and USB (format *.xml) Copies saved test results between RAM disk ¹⁾ and USB Copies the general device configuration (binary format *.dat) Copies the data of the device variant. 	<p>Access only via the Service menu</p>
<ul style="list-style-type: none"> • Direction <ul style="list-style-type: none"> ○ USB to Flash ○ Flash to USB 	<p>Selects the direction of the copy operation:</p> <ul style="list-style-type: none"> Copies the selected files from the USB device into the flash memory of the tester Copies the selected files from the tester's flash memory (or ramdisk) to the USB device 	

¹⁾ When the tester is operated in "Ethernet" mode, the results are temporarily saved in a local RAM drive.

When file type and copy direction are chosen, a selection dialog is displayed. One can choose to copy only one specific file, or to copy all files located in the respective folder.

Using the example of file type "Programs" :

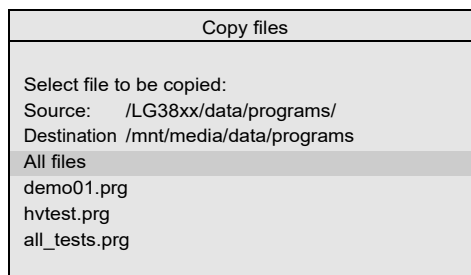

Before copying is started, there is an additional safety query whether the files really shall be copied. The copy operation starts when this query is acknowledged. As long as the safety query is displayed, the operation can be aborted by the ESC key at the device's front panel.



Folder structure for file copying

The diagram below shows the folder structure used by the tester. When copying files from the tester to a USB device, the files are copied to the respective folders. If any of these folders are not present, they are created during the copy process.

When files are copied from a USB device into the tester, it is necessary that the files to be copied are located in the correct folders on the USB device. E.g. if test programs are to be copied from USB to the tester, then those programs must be located in [root]\data\programs\ at the USB device.

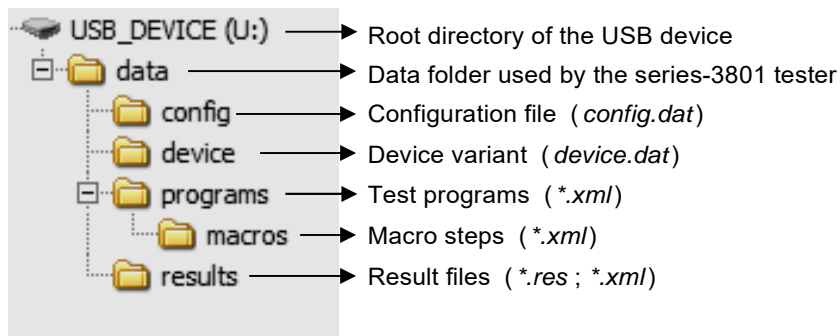

Notes:

- Filenames must not exceed 15 characters. Filenames must not contain special characters or umlaut. Filenames must not contain uppercase characters, only lowercase characters are allowed.
- Files copied into the device can only be used after performing a software reset.
The fastest method is to switch the device to another language in 'system parameters'. Alternatively, a software reset can be achieved by switching the device off, and on again.
- To use the "copy files" function, the service password must be known!
(default settings for shipping devices: "SERVICE")

5.9.4 Device ID

Here, a plaintext name can be assigned to the tester, for easier identification in a network neighborhood.

This name will be displayed in the 3800NET software running on the network server. There, a cleartext name like e.g. "Tester Band 1" is much more convenient than only seeing an IP like e.g. "192.168.90.208".

The device ID can be 15 characters long at max.

5.10 Safety - Selection of start control

Via the safety options it is specified which kind of safety control is to be applied.

Available parameters:

- **Start key** Test process is started via "Start" key of the tester
- **Probe button** Test process is started via start key of the test probe
- **Other Input** Test process is started via a signal on the I/O-interface:
 - **Test pistol** Test process is started via the connected HV-test pistols
 - **2-Hand** Test process is started via a 2-hand operation
 - **Hood** Test process is started via the signal of a test hood
 - **Test Button** Test process is started via an external start key
 - **Digital input** Specifies by which input of the I/O-interface the start signal is committed
- **Use for Start** Activates or deactivates starting the test program by the safety control
- **Check after Step** When test step has finished, a prompt to release the safety control is given

"Safety Control":

If within the test steps IS / HV the option "safety control" is not set to "Off", then a respective message is displayed after starting a test step (e.g. "push start key" or "activate 2-hand operation"). The test step will only start if the request has been complied with, i.e. if the electric circuit is closed via the respective safety control.

The possible settings for "safety control" in test steps HV and IS:

- Off** – Test step starts immediately, without checking the protective circuit.
- Impulse** – Test will start after closing protective circuit once.
- Hold** – Protective circuit has to remain closed during the complete duration of the test until the test result will be displayed. Premature release of contact will lead to abortion of the test step with the result ERROR.

Starting a test program:

If "Use for start" is activated, then a test program can be started by means of one of the "Other Input" controls.

Independent of this setting, a test program always can be started by the START key on the front panel, or by the key of a connected test prod.

End of a test step:

If "Check after Step" is activated, then at the end of a test step a prompt to release the safety control will be displayed. (Applies only if the test step uses "SK=hold".)

5.11 Printer - Setting of printer format

Here the settings for the protocolling of the test results on a printer are determined.

The output will be carried out either to a printer connected locally to the tester via the RS-232 interface X1, or over the network to a network printer. For network printing, only PostScript-compatible printers can be used. If needed, the interface settings can be adjusted in *System parameter / Interfaces* acc. to the printer's specifications.

5.11.1 Printer format

The available options are:

- **Narrow** The protocol is reduced in width to ½-DIN-A4.
- **Page** The protocol is printed in standard DIN-A4 format with form feed.
- **Endless** The protocol is printed in DIN-A4 format without form feed.
- **Line** Only a minimal protocol is printed with only one line per test.

5.11.2 Headline and footnote

Here any text which is to be printed on each page of the protocol as headline or footnote can be entered. Each text can consist of up to 30 characters.

For input of text please see the information on page 27.

5.11.3 Interfaces

Here the interface via which the printer is to be connected is selected:

- **RS-232** To use a local printer
- **IP (Postscript)** To use a network printer (only PostScript printer!)

5.11.4 Printer IP and Printer Port

This sets the network address and communication port for a network printer. This position is identical to the one listed in *System parameter / Interfaces / Ethernet*.

5.12 Maintenance – calibration and service test

Attention:

This area must only be used by SPS electronic service technicians! False settings can lead to a destruction of the device!

6 Creation of test programmes

6.1 General information

Due to the functionality of the test programmes of the IL 3801 complex test processes can be realized comfortably. Administration and organisation of various programmes for different DUT types can be carried out without problems.

It is also possible to create and use macros in test programmes. Hereby it is possible to define one's own "building blocks" of test steps, which later can be inserted into programmes as needed. This eases, for example, the programme creation when the I/O-interface is queried, and the monitoring requires the same or similar steps to be done several times.

The created test programmes are filed internally in a non-volatile memory and remain filed even if the device is completely cut off from power supply.

To operate with test programmes you select the entry "test programmes" in the main menu.

6.2 Explanation of action menu

When operating with test programmes, i.e. if new test programmes are created or existing ones are to be altered, the existing data will always be displayed list form.

To carry out an alteration, whether in the list of all existing test programmes or within a specific test programme, you select the element to be altered and push the handwheel. Now the **action menu** opens. From this menu you select the action to be carried out.

Example 1 – action menu in programme list:

Test programs		
Program	Action	Time / Nr.
TEST01	Load	07 08:56 / Nr.0
TEST02	New	UFUNG
EXAMPLE01	Edit	UFUNG
EXAMPLE02	Delete	UFUNG
	Copy	UFUNG
	Rename	UFUNG
	Edit Macros	RUFUNG
	Print	SICHT
	Print Condition	
	Program Number	

Example 2 – action menu within a test programme:

Test program detail		
Step	Action	Value
1 H1 TEST		H1 TEST
2 H1 TEST		1.0s
3 TEXT STEP	New	0.00mA
4 I1 TEST	Edit	1.00 mA
5 TEXT STEP	Rename	µs: Socket
6 IO STEP	Cut	kreis: Off
	Copy	
	Insert	: Continue
	Print	er: Finish

On the following pages the single actions are explained.

6.2.1 Load

Available: only test programme list

To carry out tests with an existing programme it needs to be *loaded* first. By doing so the selected test programme is loaded from the internal read-only memory (ROM) into the working storage.

After loading a test programme the respective screen for test operation is displayed. Then you can start the test operation with key START at the device or at the test probe.

6.2.2 New

Available: test programme list and programme editor

- If you select the action "New" from the test programme list, then a new still blank test programme is created and inserted into the test programme list which can then be edited as requested.
First a dialogue is displayed into which you enter a name for the new test programme (please see information on page 27). After input and acknowledgement of name you automatically go to mode "Edit" (pl.see below) and the new, still blank test programme is displayed.
- If calling-up from the programme editor a new test step will be inserted into the currently opened test programme. Now you will see a list with all the available test steps from which you select the requested test step. Then you go automatically to the editing mode to set the single parameters for the new test step.

Information: With the action "New" the new test programme or the new test step is inserted after the before marked element.

6.2.3 Edit

Available: test programme list and programme editor

If you select the action "Edit" then the selected test programme or the selected test step will open for operation. You can then insert or delete new test steps or alter test parameters of existing test steps.

6.2.4 Cut

Available: test programme list and programme editor

With action "Cut" the selected element (either a complete test programme in the programme list or a test step in a test programme) is cut out from the displayed list.

However, at the same time, it is copied into an internal buffer so that a later application of this element will remain possible (please see 6.2.9: relocation)

6.2.5 Copy

Available: test programme list and programme editor

Action "Copy" copies the selected element into the internal buffer, too, it remains, however, in the displayed list.

The alternating application of "Copy" and "Insert" (pl. see below) will enable you to duplicate test steps or complete test programmes quickly and easily.

6.2.6 Insert

Available: test programme list and programme editor

If you select the action "Insert" then a test step (or test programme) copied or cut-out before will be inserted behind the position of the element you have just marked.

Information: If by copying and inserting within the programme list a complete test programme is duplicated a new programme name has to be assigned for "Insert" (several programmes with the same name are not possible).
This limitation does not exist when duplicating a test step within a programme: several test steps with the same name are possible.

6.2.7 Edit Macros

Available: only test programme list

When selecting this action, the device switches to the macro-editor. Here one can create new macros and edit existing ones. (See chap. 6.4)

6.2.8 Save

Available: only test programme list

After having created a new programme and after having edited an existing programme the alterations in this action menu which have been carried out have to be *stored*. The altered data will then be written permanently into the internal read-only memory (ROM).

If the device is switched off before the storing process then the before carried out alterations will be lost.

Information: If on abandoning the editor unstored alterations still exist the device will inform you and inquire if the alterations are to be stored:

Drucken
<div style="display: flex; justify-content: space-between;"> TEST01 TEST01 </div>
Do you want to store these alterations?
<div style="display: flex; justify-content: space-around; width: 100%;"> Yes No </div>
6 TEXTSICHT

Therefore to inadvertently not store alterations carried out before is impossible.

ATTENTION: During storing process the device must under no circumstances be switched off or the power supply cut off! All test programmes can be lost then and the memory become useless!

6.2.9 Relocation of a test programme or of a test step

If, within a programme, you wish to relocate a test programme or a test step to another position you proceed as follows:

1. Mark the element to be relocated
2. Action menu → "Cut"
3. Mark the new position of the element to be relocated
4. Action menu → "Insert". (The cut-out element will be inserted behind the marked element.)

6.2.10 Printing of test programme

If you want to print a test programme including all the test steps and their parameters then you call the action menu from the test programme list or from within a test programme opened for editing, and select the item "Print" from the menu by pushing on the wheel:

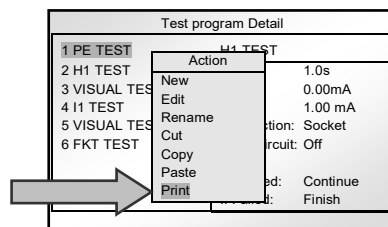

To perform above a serial printer must be connected to the RS232-interface and same has to be switched on (there is no request for both by the IL 3801).

6.2.11 Condition for printer protocolling

For each test programme you can determine individually its printer protocol, i.e. if you want the protocol to be created "always" or merely in case of "Pass" or "Fail".

This setting is carried out via the action menu: "Print Condition" from the programme list, and will be stored together with the programme.

6.2.12 Program number

For the operating mode "digital", a unique number in range 0 – 15 can be assigned to each test program. The numbering is independent of the program list's alphabetical ordering.

6.2.13 Program model

With this entry, a "model number" can be assigned to each test program. This feature is used for barcode reader operation, in order to evaluate the required test program from the read barcode.

For "model number", a complete barcode in its full length has to be entered (can also be read directly into the mask by barcode scanner). Relevant for later evaluation are only those positions that have been marked as "M" in the menu "BarcodeMask" (See chpt. 5.3.6, p. 33)

6.3 Editing test programmes and test parameters

6.3.1 General information

After selecting menu "Test Programmes" from the main menu below programme list is displayed:

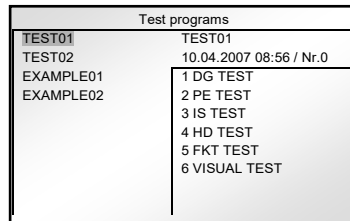

On the left side of the window you will see a list with the names of all test programmes stored.

On the right side the test steps of the programme which are marked in the list are displayed. Within a programme all test steps are numbered consecutively.

To edit a test programme you first mark the requested programme and then push the handwheel. The action menu from which you select the action "Edit" opens:

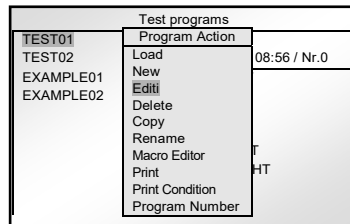

If, however, a completely new test programme is to be created you select the action "New". It does not matter then which programme was marked when calling the action menu: a new, blank test programme will be created in any case.

When creating a new test programme the request to enter a name for the programme will be made first. A *specific* name must be assigned here: Several test programmes with the same name cannot be managed parallel!

Now you can insert the required test steps via the action "New" into the test programme just created:

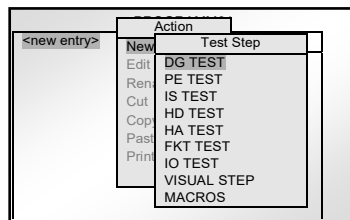

After inserting a new test step or selection of an existing test step for editing you automatically go to an editor window in which all parameters of the respective test step can be set as required.

On the following pages the parameters of all test steps will be explained.

6.3.2 Common parameters and programme settings

Common to all test steps are the lines "If Pass" and "If Fail" on the right side of the test parameter menu:

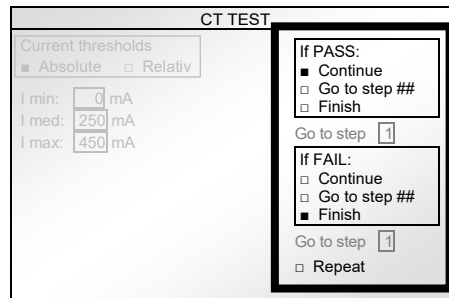

Via these two lines you can establish how to continue the test process, if the respective test steps end either with the result "Pass" or "Error":

- **Continue** Test process is continued with next test step of programme.
- **Go to step ##** You go to test step no. "##" and continue the test process from there.
- **End** Test process is ended, no further test steps are carried out.
- **Repeat** If the test step ends with "Fail", a dialogue is displayed requesting if this test step is to be repeated.
If on repeating an error-free result is achieved the test step will be rated as "PASS".

6.3.3 Continuity test (CT)

With the continuity test a voltage of 22 VDC, current limited to max. 500 mA is applied between connections **L** and **N** of the DUT, and the flowing current (up to 500 mA) is measured now.

If current values between I_{min} and I_{max} are measured, the DUT has passed the test.

In case of current values lower (than) I_{min} or higher (than) I_{max} , DUT has failed the test.

Herewith one can test:

- *Has DUT been switched on?*
- *Is there an internal short-circuit at DUT?*

CT TEST	
Current thresholds <input checked="" type="checkbox"/> Absolute <input type="checkbox"/> Relative	
I min:	<input type="text" value="0"/> mA
I med:	<input type="text" value="250"/> mA
I max:	<input type="text" value="450"/> mA
<input type="checkbox"/> Check I _{max}	
If Passed: <input checked="" type="checkbox"/> Continue <input type="checkbox"/> Go to step ## <input type="checkbox"/> Finish Go to step <input type="text" value="1"/>	
If Failed: <input type="checkbox"/> Continue <input type="checkbox"/> Go to step ## <input checked="" type="checkbox"/> Finish Go to step <input type="text" value="1"/> <input type="checkbox"/> Repeat	

Explanation of test parameters for continuity test:

<ul style="list-style-type: none"> • Absolute <ul style="list-style-type: none"> ○ I min ○ I max 	Selection of current measurement with absolute values Required minimum current for test result PASS Tolerable maximum current for test result PASS	(✓ / –) (0 – 500 mA) (0 – 500 mA)
<ul style="list-style-type: none"> • Relative <ul style="list-style-type: none"> ○ med ○ Tolerance – ○ Tolerance + 	Selection of current measurement with relative values Preset value for required average value of current Highest tolerable drop below average value Highest tolerable surpassing of average value	(✓ / –) (0 - 500 mA) (0 - 100 %) (0 - 100 %)
<ul style="list-style-type: none"> • Check I_{max} 	With this option, the checking of the upper threshold (I _{max}) can be activated or deactivated. (When deactivated, the test result is PASS as soon as there is continuity, no matter whether e.g. 5 mA or 1 A.)	(✓ / –)

6.3.4 Insulation test (I2)

The insulation test I2 tests the electric strength between current-carrying cables L and N and protective conductor PE (or other connections).

In case of insufficient or damaged electric strength of the DUT an arc-over will occur.

I2 TEST	
Test time:	<input type="text" value="1.0"/> s
Ramp time:	<input type="text" value="1.0"/> s
Ramp start:	<input type="text" value="100"/> V
U nom:	<input type="text" value="1000"/> V
R min:	<input type="text" value="5.00"/> MOhm
Ramp down:	<input type="text" value="No"/>
Ramp error:	<input type="text" value="Normal"/>
I R min / max:	<input type="text" value="0.00"/> <input type="text" value="1.00"/> mA
Connection:	<input type="text" value="test pistol"/>
Safety control:	<input type="text" value="off"/>
If pass: <input checked="" type="checkbox"/> Continue <input type="checkbox"/> Go to step ## <input type="checkbox"/> Finish	
Go to step <input type="text" value="1"/>	
If fail: <input type="checkbox"/> Continue <input type="checkbox"/> Go to step ## <input checked="" type="checkbox"/> Finish	
Go to step <input type="text" value="1"/>	
<input type="checkbox"/> Repeat	

Explanation of test parameters for I2 insulation test:

• Test time	Preset value for duration of test (without ramp)	(0.1 – 999.9 s)
• Ramp time	Duration of time for voltage ramp when starting test	(0.0 – 999.9 s)
• Ramp Start.	Initial value for voltage with voltage ramp	(Serie F: 100 – 3000 V) (Serie G: 100 – 4000 V)
• U nom	Preset value for test voltage	(Serie F: 100 – 3000 V) (Serie G: 100 – 4000 V)
• R min	Required minimum resistance for PASS-result	(Serie F: 0.25 – 1500.00 MOhm) (Serie G: 0.25 – 2000.00 MOhm)
• Ramp down	Selection of a dropping voltage ramp at the end of test	(✓ / –)
• Ramp error	Method of current control during voltage ramp (<i>expl. p. 74</i>)	(Extra/MBE)
• I R min / max	Required minimum / maximum current during voltage ramp	(0.0 – 3.99 mA)
• Safety control	Selection whether external protective circuit is to be queried	(Off/Impulse/Hold)

Parameter "Safety control":

Please see the explanation in chapter 5.10 – "Safety - Selection of start control", page 42.

Note:

The Insulation Test is always performed in 2-wire-technique, regardless of the system parameter settings. Therefore, the DUT has to be connected in 2-wire-technique, too. Otherwise, the measuring module's inner resistance of 100 MOhm would be included in the measured section.

6.3.5 High voltage test (H2)

The high voltage test H2 tests the electric strength between the connected potentials.

In case of insufficient or damaged electric strength of the DUT an arc-over will occur.

H2 TEST	
Test time:	<input type="text" value="1.0"/> s
Ramp time:	<input type="text" value="1.0"/> s
Ramp start:	<input type="text" value="100"/> V
U nom:	<input type="text" value="1000"/> V
I min / max:	<input type="text" value="0.00"/> <input type="text" value="1.00"/> mA
Ramp down:	<input type="text" value="No"/>
Ramp error:	<input type="text" value="Normal"/>
I R min / max:	<input type="text" value="0.00"/> <input type="text" value="1.00"/> mA
Safety control:	<input type="text" value="off"/>
If pass: <input checked="" type="checkbox"/> Continue <input type="checkbox"/> Go to step ## <input type="checkbox"/> Finish	
Go to step <input type="text" value="1"/>	
If fail: <input type="checkbox"/> Continue <input type="checkbox"/> Go to step ## <input checked="" type="checkbox"/> Finish	
Go to step <input type="text" value="1"/>	
<input type="checkbox"/> Repeat	

Explanation of test parameters for high voltage test:

• Test time	Preset value for duration of test (without ramp)	(0.1 – 999.9 s)
• Ramp time	Duration of time for voltage ramp when starting test	(0.0 – 999.9 s)
• Ramp start	Initial value for voltage with voltage ramp	(Serie F: 100 – 3000 V) (Serie G: 100 – 4000 V)
• U nom	Preset value for test voltage	(Serie F: 100 – 3000 V) (Serie G: 100 – 4000 V)
• I min / max	Required minimum / maximum test current for PASS result	(0.0 – 3.9 mA)
• Ramp down	Selection of a dropping voltage ramp at end of test	(✓ / –)
• Ramp error	Method of current control during voltage ramp (<i>see p. 77</i>)	(norm/extra/MBE)
• I R min / max	Required minimum / maximum current during voltage ramp	(0.0 – 3.99 mA)
• Safety control	Selection whether external protective circuit is to be queried	(Off / impulse / hold)

Parameter "Safety control":

Please see the explanation in chapter 5.10 – "Safety - Selection of start control", page 42.

6.3.6 I/O-test

By means of the I/O-test it is possible to transmit signals on the I/O-interface or to read incoming signals. This way external systems can be controlled, or the test process can be controlled dependent on the condition of external systems by branching via the "If-Pass / If-Error" - conditions depending on the read-out result.

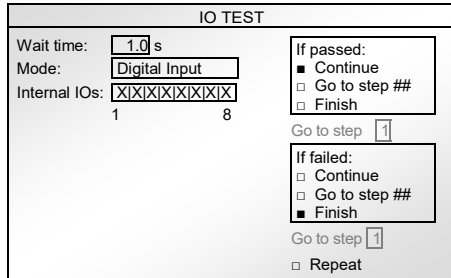

Reading of digital Input
(standard device)

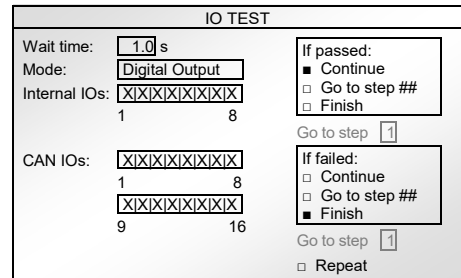

Setting of digital Output
(device with CAN extension)

Explanation of test parameters for I/O-test:

<ul style="list-style-type: none"> Mode: Digital inputs <ul style="list-style-type: none"> Wait time: Period of time during which the signal input is read (0.1 – 999.9 s) Internal/external IOs: Indicates the awaited bit combination on reading (0/1/X) 	<p>Configuration to read signals via I/O-interface</p>
<ul style="list-style-type: none"> Mode: Digital outputs <ul style="list-style-type: none"> Wait time: Waiting time from call-up of step to setting of signals (0.1-999.9 s) Internal/external IOs: States which outputs are to be set or deleted (0/1/X) 	<p>Configuration to set outputs of I/O-interface</p>

Information:

- Only if in *System Parameters* under *operating mode* → *Manual* option "digital output" has been **deactivated**, all eight in- and outputs are available for the I/O-test!
 If "digital output" is **activated**, the I/O-interface for standard status signals and control signals is applied and not all in- and outputs will be available. (pl. compare next page and annex).
- For each in- or output "0", "1", or "X" can be specified:

 - 0 – Signal must be (read) "low" or will be set (written) on "low"
 - 1 – Signal must be (read) "high" or will be set (written) on "high"
 - X – Signal condition is ignored (read) or remains unchanged (written)
- When **reading** the specified bit combination must be read exactly from the digital inputs to achieve the test result PASS. Inputs specified with "X" will be ignored.
- After starting test step the space of time of [test time] is awaited. If by process end of test time the specified bit combination has not been achieved, the test result will be ERROR.

- When **setting** signal outputs all outputs specified with "0" are set on "low" and those specified with "1" are set on "high". The status of outputs specified with "X" will remain unchanged.
- After starting the test step the outputs are set immediately. Then you wait for the space of time [delay] before ending the test step and the next one is started. This can be applied if parts of the controlled external systems will need a certain space of time to convert the signals received.

Availability of digital in- and outputs for I/O-step

Mode "Manual", "digital output" = YES	Mode "Manual", "digital output" = NO	Mode "Digital", "Programme selection" = NO	Modus "Digital", "Programme selection" = YES
output 1	output 1	output 1	output 1
output 2	output 2	output 2	output 2
output 3	output 3	output 3	output 3
output 4	output 4	output 4	output 4
output 5	output 5	output 5 ¹⁾	output 5
output 6	output 6	output 6	output 6
output 7	output 7	output 7	output 7
output 8	output 8	output 8	output 8
input 1	input 1	input 1	input 1
input 2	input 2	input 2	input 2
input 3	input 3	input 3	input 3
input 4	input 4	input 4	input 4
input 5	input 5	input 5	input 5
input 6	input 6	input 6	input 6
input 7	input 7	input 7	input 7
input 8	input 8	input 8	input 8

¹⁾ Output 5 used in operation mode »Ethernet« for signalling of Network errors

Explanations:

- The in- and outputs marked in dark must not be applied for the I/O-step: their condition must be considered, because of different assignment, as "undefined".
- If in case of test steps IS or HV option "protective circuit" is activated, another input for this function is assigned (adjustable under *System Parameter* → *Safety*), and is thus not applicable for the I/O-test.
- In Remote-operation the I/O-test does not exist as individual test step, in this case the inputs are read via requests INP? or INPW? and set via request SET. Here, too, the input is not applicable if the protective circuit function is applied for the IS- and/or HV-test (via requests CONF:xx:SKTYP and CONF:xx:SKINP).

6.3.7 Analog I/O

By means of the test step "Analog I/O" it is possible to read the actual values of the analog inputs **AI1** / **AI2**, or to set the analog output **AO** to a certain value.

Similar to the test step "I/O Test" this enables to control external systems, or to control the flow of the test program by branching via the "if passed / if failed" – conditions, dependent on the value read from the input.

Reading of analog input

Explanation of test parameters for Analog I/O:

• Waiting time	Duration of the test step	(0.0 – 999.9 s)
• Mode	Switches between "Input" (reading) and "Output" (writing)	
• Analog Input	Chooses the input to read from	(AI1 / AI2)
○ Val. range Min / Max	Allowed input range for test result PASS	(0 – 100)

Information:

- When **reading** an analog input, the input signal must reach the specified value range within the timespan [Waiting time], and also must be in range at the end of the waiting time period. Only then the test result is PASS. In any other case, the result is FAIL.

6.3.8 Text step / visual test

This test step can be carried out in two different methods: as *Text Step* or as *Visual Test*.

This text step can, for example, be used to give instructions to the operator: "Connect DUT now!".

In case of the visual test the PASS/ERROR result will depend on the visual judgement of the operator.

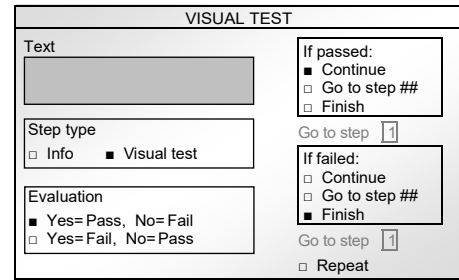

Explanation of test parameters for text step:

• Text	Entry of inquiry or information text	(max. 30 characters)
• Step type	Selection of test method:	
○ Info	The indicated text is displayed to the operator and can only be acknowledged with OK. There is <u>no</u> test result PASS or ERROR.	(✓ / -)
○ Visual test	The indicated inquiry is displayed to the operator and can be answered by YES or NO. Depending on the answer the result of the step will be PASS or ERROR.	(✓ / -)
• Evaluation	With this option the logics can be changed over for answer evaluation in order to be able to also evaluate "inverse" question logically: <i>"Is the DUT red hot?" → "No" ⇒ test result PASS.</i>	
○ Yes = pass, No = fail		
○ No = pass, Yes = fail		

There is no umlaut or any special character available.

6.4 Using macros in test programmes

6.4.1 Overview

The term "macro" is used for groups of test steps that are managed as one unity each, and have their own name assigned. During the process of creating or editing test programmes, these macros are used the same way as normal test steps are.

In a sense, macros could be seen as "mini test programmes", since they consist of one or several test steps just as a normal test programmes do.

The difference is that macros are used to prepare "building blocks", which later can be used to create complex test programmes very easily by just putting together the needed "blocks".

Example:

A high voltage test in conjunction with I/O-interface control is used frequently. Before and after the high voltage test, always the same I/O-test steps must be performed to send or read control signals to or from the I/O-interface.

If macros were not available, for each test program one would have to insert the needed I/O-steps one by one and to configure each of them individually, or to copy/paste all single steps from a reference programme.

By means of the macro functionality, the effort becomes much smaller. One single time, an according macro step is created: (schematic example)

```
*ExampleMacro
- I/O-step( [read status] )
- I/O-step( [set signal s] )
- High voltage test
- I/O-step( [reset signal s] )
- I/O-step( [read status] )
```

and is stored in the device with an appropriate name. In future, if this combination of test steps is needed, one will simply insert the macro "*ExampleMacro" into the test programme, and is done.

There is no limit for the number of macros that can be stored. Stored macros are itemised in a separate list, similar to the test programme list.

6.4.2 Creating and editing macros

The creation of a new macro is done in a similar way as for test programmes:

programme editor → *action menu* → *"edit macros"*

After this, the list of macros is shown instead of the list of test programmes. Now one can create new or delete old macros, insert test steps into macros, change the parameters of test steps within macros, etc.

All these operations are done in the same way as described in *6.3 – Editing test programmes and test parameters*.

6.4.3 Inserting macros in test programmes

After the needed macros have been created, they can be inserted in test programmes just as if they were "normal" test steps. The only difference is that the selection is made from an additional list:

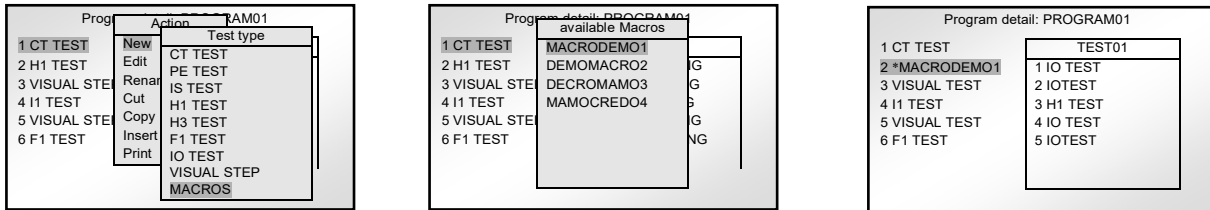

Choosing "new – macros" ...

... selection of the needed macro ...

... after confirming the selection.

Within the program listing, macro steps are indicated by an asterisk (*) after the test step number:

```

1 CT TEST
2* MACRODEMO1
3 TEXT STEP
.
.
.
    
```

6.4.4 Editing macros within test programmes

After a macro step has been inserted into a test programme, the parameters of the test steps included in the macro can still be edited. This is done in the usual way by selecting the macro step and choosing "edit" from the action menu.

Restrictions:

- Once a macro has been put into a test programme, it is not possible to delete test steps from it, or to add new test steps to it.
For this reason, the operations *copy/cut/past* are not available, too.
- The test step "I/O test" can not be edited at all.
(This restriction deals for reliable reproduction of hardware controlling tasks through macro steps.)

7 Performing tests in manual operation

7.1 General information

In manual operation tests can be performed in two different methods:

1. Testing with pre-set test programmes
2. Single test operation

Test operation with test programmes is the recommended mode for serial test operation. You can carry out complex sequences of test steps or you can keep statistics on the results, print protocols, etc.

The single test operation is suitable for performing single tests with changing test parameters quickly and easily in sequence. To be able to find, for a new type of DUT, the appropriate test parameter to create a new test programme, the single step operation can be recommended.

Further possibilities for single DUTs could e.g. be special tests or tests for error finding – to create a programme for this purpose alone would be too time-consuming.

Notice to: "Device is part of a test system"

When the device is integrated into a test system, then the manual "Single-test" mode often is not usable. E.g. when the test voltages are transmitted by an interlinked module (like "V1") to the DUT, the test voltages might not actually get to the DUT when the system is not in operation.

7.1.1 Preparations ahead of test operation

Before starting a test operation all the relevant basic settings should have been carried out. Especially

- type of measurement (2/4-wire) → chapter 5.7.1, p. 35
- display of measurement results → chapter 5.7.2, p. 36
- printer protocol settings → chapter 5.11, p. 43f.
- creation of test programmes → chapter 6, p. 44ff.

7.2 Program menu during test operation

If the device IL 3801 is in test mode "Testing" (i.e. if a test programme has been loaded from the programme list) the Quick menu can be displayed via the operating key MENU . Same provides further functions to organize the test process:

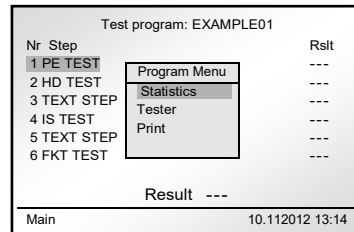

7.2.1 Statistics

For each test programme an internal statistics is kept about the test results. Via this menu the statistics can be read or deleted.

Please see also chapter 7.5, p. 62.

7.2.2 Tester

Here can – and should – the name of the person performing the tests be entered.

After selection of the menu the regular text entry dialogue is displayed into which, as explained under 4.3.1, the name is entered:

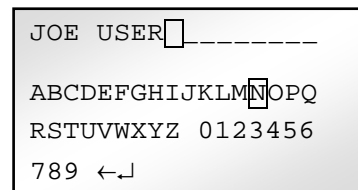

Information:

- The name of the tester entered here will appear in all test protocols later on.
- The once entered tester name remains valid until either a new name is entered or the IL 3801 is switched off and on again.

7.2.3 Printing

By selecting this menu the currently loaded test programme is written out on a connected printer. The data output is carried out immediately, there will be no further messages or acknowledgements.

7.3 Test programme process

7.3.1 Outline

- **Loading of test programme**

After loading a programme the programme outline will be displayed:

Test Program: EXAMPLE01		
Nr	Step	Result
1	CT TEST	---
2	HD TEST	---
3	VISUAL TEST	---
4	IS TEST	---
5	VISUAL TEST	---
6	FKT TEST	---
Result		---
Main		10.11.2012 13:14

- **Start of test**

The test start is carried out according to set start control. Pre-set is the START key of the IL 3801.

- **Test step process**

The test steps are consecutively carried out with their programmed parameters.

Depending on test step and set start control the single steps will start automatically or when contacting DUT or after activating start control.

While one test step is in process the current measuring values are displayed.

- **Test step result**

If one test step ends with PASS, the next step will start immediately.

If one test step ends with ERROR, the test process is stopped (if under "if Error" of the respective step nothing else was specified)

- **Test result**

If all test steps resulted in PASS, the complete test result is PASS.

The programme will be started again with the 1. test step.

If the test step result was ERROR, the complete test result is ERROR.

The test process is stopped and the faulty step is displayed:

Test program: EXAMPLE01		
Nr	Step	Result
1	CT TEST	OK
2	HD TEST	OK
3	VISUAL TEST	OK
4	IS TEST	NOK
5	VISUAL TEST	---
6	FKT TEST	---
Result		NOK
MAIN		10.11.2012 13:14

In the manual test mode you can now either

- start again the next test with START or
- examine the measuring values of the test process (pl. see 7.6.1, p. 63)

In digital operation the faulty test must possibly first be acknowledged by an EXT_ACK signal before being able to start the following test process with EXT_START.

This will depend on the setting "*Acknowledgement*" in *System Parameter* → *Operating Mode* → *Digital*.

7.4 Changing of test programme

In order to be able to continue the test process with another test programme below steps have to be carried out:

0. *(Test process of current programme has to be finished)*
1. Push key ESC
⇒ Jump back to list of test programmes
2. Selection of requested programme from list
3. Push handwheel → Action menu "Load"

The new test programme is now loaded and the test operation can be continued with this programme.

7.5 Statistics

An internal statistics is kept for each test programme. In the statistics the results of all individual steps as well as all of the total results of the individual test programme are protocolled.

The statistics module can be called up via MENU → "Statistics".

The PASS results (OK) and ERROR results (NOK) are counted for each single test step of the respective programme, counted are also the total results of the test programme.

With menu "Print" the statistics can be written out by a printer.

Via entry "Delete" the statistics can be deleted, i.e. all values can be set back to zero.

Statistics			
Nr	Step	OK	NOK
1	PE TEST	7	0
2	H1 TEST	7	0
3	VISUAL TEST	7	0
4	I1 TEST	7	0
5	VISUAL TEST	6	1
6	F1 TEST	6	0
EXAMPLE01		6	1
Print		Delete	

Information:

- The statistics is constantly actualized in the background during the test process. It doesn't have to be stored or activated.
- If a new test programme is created by "copying" an existing programme, the existing statistics will **not also** be copied. The newly inserted programme will start over with a "blank" statistics.

7.6 Test results and test protocol

The results of tests or the measurement values of single test steps can be read in two different ways:

- On the display of the tester
The result is always displayed on the device display in compressed form. And only the results of the respectively most recent programme process can be read.
- On the print-out of a connected protocol printer
The printer protocolling supplies a detailed result protocol of all tests performed.

7.6.1 Readout of result on display

The measurement results of the most recent test process can be read on the device display. To do so the IL 3801 must come to a stop, i.e. the device either waits for acknowledgement after a faulty test or a test was stopped by the operator.

If you select now a test step from the programme outline (please see p. 61 below) by handwheel the results of this test step will be displayed in a new window:

EXAMPLE01				
Test Step: 2				
HD TEST				
	min	max	Actual	Result
I	0.00mA	3.00mA	1.37mA	OK
U	1500.00V	2000.00V	2376.50V	NOK
Tester		JOE USER		
		10.11.2012 13:14		

With key ESC you will return to the programme outline. Now measurement values of other test steps can be examined or, after required acknowledgement, the test operation can be continued.

7.6.2 Printer protocolling

Protocolling on a printer will supply detailed data on all test steps performed.

If a printer is connected to RS-232 interface **X1** and switched on the protocolling will be automatic.

Four different formattings for the printer protocol are available:

- **Narrow** The protocol is printed in reduced width, e.g. for roll paper.
- **Page** The protocol is formatted to DIN A4 page size, with a headline and a footnote on each page.
- **Endless** The protocol is formatted as in "Page", however without form feed and without footnote. Same is suitable for endless roll paper as well as for other than A4 paper lengths if the form feed is controlled by the printer.
- **Line** This only creates a minimal protocol with only one line per test.

The required formatting can be set with *System Parameter* → *Printer* → *Print Format*.

8 External control: operating modes Remote, Digital, Ethernet

The application possibilities of our tester IL 3801 are not limited to manual tests. By means of operating modes "Remote" and "Digital" the IL 3801 can also be applied for automated or remote-controlled test operations.

8.1 Operating mode Remote

8.1.1 General information

In Remote operation the tester is controlled completely via digital command sequences. The advantage of this control method is that you do not absolutely depend on rigid processes of the preset test methods. It is, on the contrary, possible to use and control all functions of the IL 3801 independently. You can especially realize control circuits in the sense of "Measure, Control, Adjust" via the remote controlling device. Same will allow also its operation in very specific application situations in which the possibilities of pre-confectioned test processes are not always sufficient.

The test programmes stored in the device will not be applied in this mode. The current system parameters at this moment remain valid can, however, if required, be passed over with respective commands.

Communication is carried out via the rear interfaces (RS-232, USB, Ethernet). The command sequences are transmitted in ASCII code. The remote control is carried out best via a PC or also e.g. via memory programmable controls (SPS).

8.1.2 Selection of Remote operation

Setting device to operating mode "Remote": (pl. compare p. 26)

Main menu → *System parameter* → *operating mode* → "Automatic"

As soon as operating mode "Automatic" has been acknowledged, IL 3801 is in Remote operation and this operating mode will be displayed:

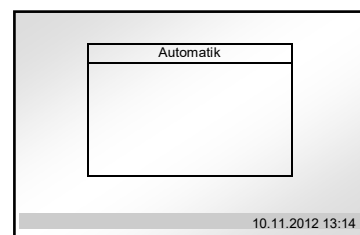

Manual operation is no longer possible. The device now awaits commands via the active interface and can be controlled by means of the commands explained in annex A – Remote Control.

8.1.3 Remote operation escape

In activated automatic operation the device remains in this operating mode even after switching off and on again.

To leave this remote operating mode you have to push key **ESC** on the front panel of the tester longer (approx. for 3 seconds). Then the device has returned to the manual mode.

The longer activation of **ESC** is necessary to prevent an unintentional quitting of the Remote operation.

8.2 Operating mode Digital

8.2.1 General information

Operating mode "Digital" is the second possibility to operate the IL 3801 automatically.

In this mode the test operation is carried out by means of pre-created test programmes as in manual operation. Selection of test programme and start of test process is performed via signals on the I/O-interface **X6**.

This way you do not need to rely on a fixed sequence of test steps or test programmes but you are able to keep the test process flexible at any time. Another possibility would e.g. be to perform the operation of the daily test operation completely via external operating units in case the tester has to be positioned in areas not easily reachable.

8.2.2 Selection of Digital operation

Setting device to operating mode "Digital": (pl. compare p. 26)

Main menu → System parameter → Operating mode → "Digital"

As soon as operating mode "Digital" has been acknowledged the IL 3801 is in digital operation and this operating mode will be displayed:

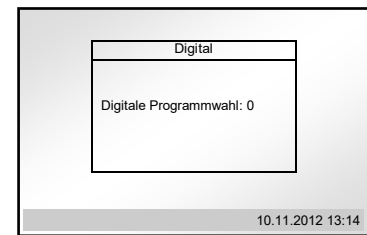

Manual operation is no longer possible. The device awaits now digital programme codes and the start signal via interface **X6** ("ext. I/O")

8.2.3 Digital operation escape

In activated digital operation the device remains in this operating mode even after switching off and on again.

To escape this digital operating mode you have to push key **ESC** on the front panel of the tester longer (approx. for 3 seconds). Then the device has returned to the manual mode.

The longer activation of **ESC** is necessary to prevent an unintentional quitting of the digital operation.

8.2.4 Digital programme selection

In digital operation the test programme is determined via the 4 Bit of PINs 11-14 of interface **X6** which is started by the start signal on PIN 18.

You can select 16 different programmes with the number of the test programme resulting from its place in the programme memory. The Offset is determined by the 4 inputs $2^0 - 2^3$, same is added to the 1. programme. (Pl. see annex B-1, p. 82f.).

As soon as signal EXT_START on PIN18 is given, the programme specified by the inputs 1- 4 is loaded and started.

Information:

The digital programme selection is only possible if the entry "*Programme Selection*" in *operating mode* → *Digital* has been activated before. If this entry has not been activated, then the test programme can only be loaded manually.

By deactivating the digital programme selection the inputs 1- 4 on interface X6 can additionally be used for control tasks by means of test step "I/O-test".

8.2.5 I/O-test in digital operation

In digital operation the I/O-interface X6 is only available within limits:

- the inputs 6 and 8 are always used for the signals ACK (acknowledgement) or START
- the inputs 1–4 are always used for the digital programme selection (if not deactivated)
- the outputs 1–4 are always used for the status signals.

Therefore in digital operation only outputs 5–8 and inputs 5 + 7 or 1–5 + 7 are available.
(Please also see table p. 54)

8.3 Operating mode Ethernet

8.3.1 General information

In operating mode "Ethernet" it is possible to include any number of testers into the network in which the test operation is administered by a central server-PC.

Function principle of network operation:

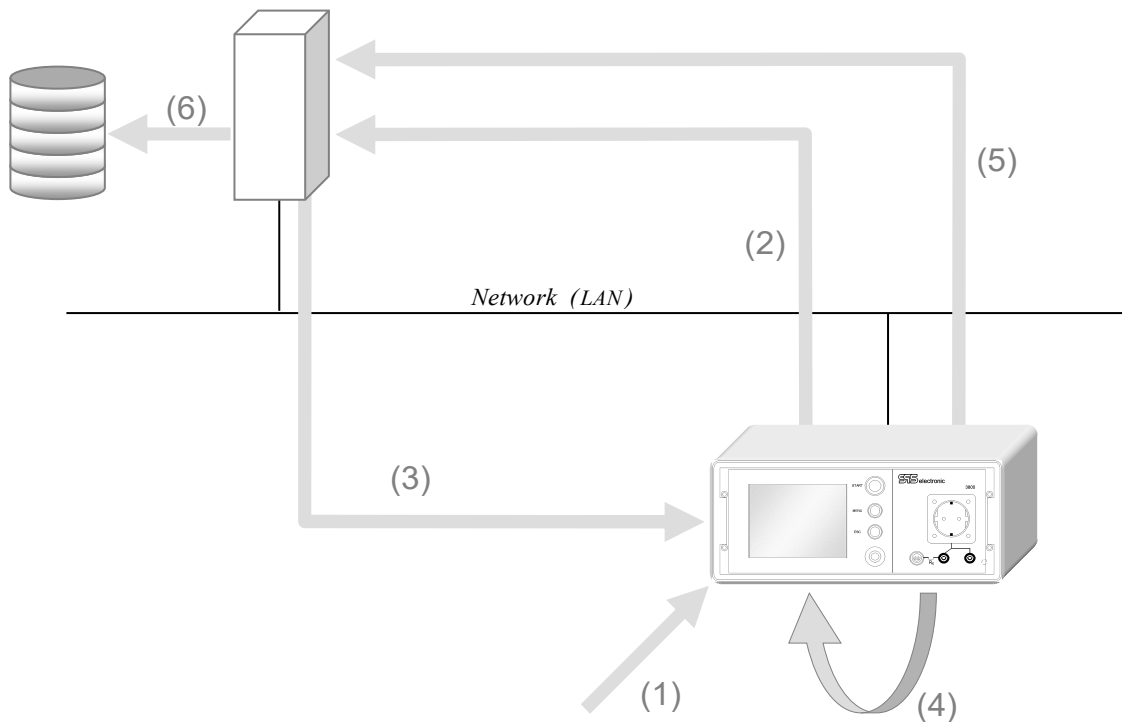

Process of a test:

Mode: NET 3800

- (1) read-in of Barcode
- (2) Barcode is transmitted to server
- (3) Server loads the suitable test programme into the tester
- (4) Performance of test
- (5) Test result is transmitted to server
- (6) Server administers test result (data base)

Mode: NET 3800 LIGHT

- | | |
|--|--|
| — | (1) Required test programme is loaded manually from device's internal programme memory |
| — | (4) Performance of test |
| (5) Test result is transmitted to server | (5) Test result is transmitted to server |
| (6) Server administers test result (data base) | (6) Server administers test result (data base) |

8.3.2 Selection of Ethernet operation

Setting device to operating mode "Ethernet": (pl. compare p. 26)

Main menu → System parameter → Operating mode → "Ethernet"

As soon as operating mode "Ethernet" has been acknowledged the IL 3801 is in network operation and this operating mode will be displayed:

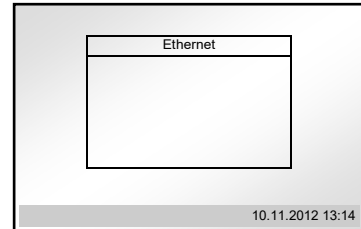

Manual operation is no longer possible. The device awaits the entry of a Barcode per Barcode scanner to start a test cycle.

8.3.3 Ethernet operation escape

In activated network operation the device remains in this operating mode even after switching off and on again.

To escape operating mode "Ethernet" key **ESC** on the front panel of the tester has to be pushed longer (approx. for 3 seconds). The device has now returned to the manual mode.

The longer activation of **ESC** is necessary to prevent an unintentional quitting of the network operation.

9 Service and function inspection

9.1 Service

Our safety tester IL 3801 is maintenance-free.



Pull power plug before opening device!



SPS electronic GmbH recommends to return the devices of series IL 3801 **for inspection once a year** to guarantee the accuracy of the measurement values.

If on inspection defects are detected the device has to be re-calibrated by *SPS electronic GmbH*.

9.2 Function check

9.2.1 Dummy test

To check the functions of the tester, or if you suspect there is a malfunction, you should perform a dummy test at regular intervals:

To do so please perform insulation or high voltage tests with your device at:

- **one or several DUTs which will, under no circumstances, pass these tests**
and
- **at DUTs for which measurement results are available which have been determined in some other way**
or
- **at a suitable test dummy with which simulations of PASS or ERROR situations can be carried out.**

Please compare the results of the different measurements afterwards.

If the measurements both result in PASS and ERROR then your device functions optimally.

Upon delivery, the device contains a test program "dummy". In conjunction with a test dummy (available separately), this test program is dedicated to perform adequate dummy tests.



Annex

A Remote Control

A-1 General

RS-232 parameter: 9600 baud, no parity, 8 bits, 1 stop bit
 Line terminator: All commands and answers are finished with <LF> (= line feed).

A-2 Syntax description

Command format

[command]<LF> maximal length 40 characters, terminated with <LF>

Answer format

[answer]<LF>

Commands

*[global command] permanently available command
 [local command] Structure dependent command, availability depending on device variant and device status (i.e. actual position during test run)

Global and local comands

[execute command] controls testing device directly.
 [configuration command]<SP>[parameter] sets device parameters (<SP> = space)
 [data request command]? Reads a value from the device. All configuration commands (CONF: XX: ...) also allow reading back by "?".

Format of parameters

[string value] May contain any character, except <LF> and " ; ",
 String length is limited to 40 characters max.
 [numerical int. value] Simple integer value, as for i.e. "number of digital input", etc.
 [numerical real value] Fixed format NNN.N (leading zeroes may be omitted), as used i.e. for all time based values (test time, ramp time, pass time).
 Floating point format N.NNE+/-NN
 Used for parameters and measured values of voltage, current, resistance, etc. For these values, basic units are used.

A-3 Global Commands

- *IDN? Reads the device identification (device type, firmware version)
Answer example: IL3801E, Ver. 1.0.2, 09.09.2004<LF>
- *VER? Reads the command version (version ID). The answer is in range 0-65535.
Answer example: 911<LF>
(See: annex A-5 / "Command version", p. 79.)
- *EXT? Reads the configuration of device extension unit. Answer is a string of 10 characters. Default answer is "0000000000" = no extension.
Answer example: 0000000000<LF>
0000100000<LF>

position	meaning	value = 0	value = 1	value = 2
1-4	EW3301 units	always 0		
5	16 I/O unit	no extension unit	extension present	
6 - 10	reserviert	always 0		

- *MOD? Reads the actual operating mode of the device. Value is in range 0-255.
Answer example: 5<LF>
(See: annex A-5 / "device mode", p. 79.)
- *STA? Reads the status register describing the current activity while the device is performing a test . Value is in range 0-255.
Answer example: 3<LF>
(See: annex A-5 / "status register", p. 80.)
- *ERR? Reads the first saved (i.e. the oldest) error from error queue, and removes it from queue. Error number (range: 0 – 255) and error description are separated by " , ".
The error queue can save a maximum of 10 errors. If the queue is full, the error "200,Queue Overflow" is saved on last position of the queue.
Answer example: 0, No error<LF>
(See: annex A-5 / "error status", p. 81.)
- *CEQ Clears all errors from the error queue.
- *CLS Clears status register, error queue, input and output buffers for serial communication. Breaks any running test and puts the device in idle state. Parameters set by commands CONF remain, however type and result of last test are cleared. Does not change *LLO status.

*RST	<p>Resets the device to power on conditions. It's the same as the *CLS command, however all test parameters are set back to default values, too.</p> <p>Moreover, *LLO status is set to "0" (default value).</p>
*LLO / *LLO?	<p>Disables the possibility to abort a test by the ESC key, resp. reads its current status.</p> <p>Possible answers: 0 = abort enabled, 1 = abort disabled</p>
*INP <digital input>?	<p>Reads the status of digital inputs. The external digital inputs are in range 1-8, the internal are in range 9-16. Possible answers are "0" (= off) or "1" (= on). The value for <digital input> must be in format NN, i.e. a 2-digit integer value.</p> <p>Answer example: 0<LF></p> <p>Some internal digital inputs are used to read the status of standard control elements:</p> <ul style="list-style-type: none"> 09 = button START on front panel 10 = start button on test probe (for PW test), start button of HV pistols in HV test (for HA38xx) 11 = button DEVICE ON (for KT38xx) 12 = button DEVICE NOT-AUS (for KT38xx) <p>(More values can be added during device series development.)</p>
*INPW?	<p>Reads all inputs (external 1-8 and internal 9-16) and puts the result in a variable (type 'word', range 0 - 65535).</p> <p>Answer example: 1030<LF></p> <p>Result evaluation: 1030 (dec) = 10000000110 (bin)</p> <p>⇒ ext. inputs 2, 3 and 11 are "on", all others are "off"</p>
*SET <RRR>; <SSS>	<p>Sets or clears signals at external digital outputs (outputs 1-8). RRR is an 8-bit decimal number from 000 to 255. By combining the corresp. binary value through logical AND the masked outputs are resetted.</p> <p>SSS is an 8-bit decimal number from 000 to 255. By combining the corresponding binary value through logical OR the masked outputs are set.</p> <p>Examples:</p> <ul style="list-style-type: none"> *SET 255;000 clears all outputs *SET 000;255 sets all outputs *SET 000;004 sets output No. 3

A-4 Local commands

MEAS? Reads the actually performed test type. If no test is performed at the time of reading, the answer is "??".

Continuity Test (CT)

MEAS: CT Starts the continuity test (CT).

READ: CT: CURR? Reads the actual value of current . Result is in [A].

Insulation Test (I1)

CONF: I 1: TIME <test time>|? Sets the test time: range 0.1 - 999.0, default 5.0 [s].

CONF: I 1: RES: 5M|50M|? Sets the measuring range to 5 M Ω or 50 M Ω , default 5 M Ω .

CONF: I 1: CON: SOCK|PROB|? Selects the connection type of tested device:
 SOCK – socket (for devices of safety class 1), default
 PROB – test probe

CONF: I 1: SKTYP: OFF|IMP|HOLD|? Selects the starting mode:
 OFF – test starts immediately
 IMP – test is started by an impulse applied to the digital input defined by SKI NP (see below), default
 HOLD – test is started by a signal on the defined digital input. Signal must apply during the whole test.

CONF: I 1: SKI NP <input nr.>|? Safety contact: specifies the number of the digital input by which the command SKTYP checks safety contact's status.
 <input nr.> is in range 1-16 (1-8 = external inputs, 9-16 = internal inputs).

CONF: I 1: DEF Resets all parameters for the Insulation Test (I1) to their default values.

MEAS: I 1 Starts the Insulation Test (I1) with a fixed voltage of 500 V DC.

READ: I 1: VOLT? Reads the actual value of real voltage. Result is in [V].

READ: I 1: CURR? Reads the actual value of real current. Result is in [A].

READ: I 1: RES? Reads the actual value of real resistance. Result in [Ω]

Insulation Test (I2)

CONF: I2: TIME <test time> ?	Sets the test time: range 0.1 - 999.0, default 5.0 [s].
CONF: I2: RAMP <ramp time> ?	Sets the time of voltage ramp at the beginning and (optionally) at the end of a test: range 0.0 - 999.0, default 1.0 [s].
CONF: I2: RDWN: ON OFF ?	Chooses whether to use the ramp-down feature or not: OFF – voltage ramp at test's end disabled (default) ON – voltage ramp at test's end enabled
CONF: I2: USTART <U start> ?	Sets the starting (resp. ending) value for the voltage ramp at a test's beginning (resp. ending). General range is 0 - 6000, default 0 [V]. However this value must be smaller than or equal to <U nom>.
CONF: I2: UNOM <U nom.> ?	Sets the nominal test voltage: general range is 100-6000, default 500 [V]. The real upper limit is either 3000, 4000 or 6000 V, depending on the device variant.
CONF: I2: RERR: EXTRA MBE ?	Sets the method of current checking during (start) voltage ramp: EXTRA – Device doesn't check real current at all (can be done externally, e.g. by a PC), default MBE – the maximally allowed ramp current is determined by HV generator's upper limit (either 2, 4 or 10 mA, depending on device type). The measured current is compared with the max. possible value; if the latter is reached, the test is aborted with error status=130.
CONF: I2: CON: SOCK PROB SK2 ?	Sets the method of DUT connection: SOCK – socket (for devices of safety class 1), default PROB – test probe SK2 – socket (for devices of safety class 2) <i>Mode SK2 is available only in some devices (see the list GerätespezMenü.xls).</i>
CONF: I2: SKTYP: OFF IMP HOLD ?	Sets the starting mode: OFF – test starts immediately IMP – test is started by an impulse applied to the digital input defined by SKINP (see below), default HOLD – test is started by a signal on the defined digital input. Signal must apply during the whole test.
CONF: I2: SKINP <input nr.> ?	Safety contact: specifies the number of the digital input by which the command SKTYP checks safety contact's status. <input nr.> is in range 1-16 (1-8 = external inputs, 9-16 = internal inputs).
CONF: I2: DEF	Resets all parameters for Insulation Test (I2) to their default values.

MEAS: I 2	Starts the Insulation Test (I2).
READ: I 2: VOLT?	Reads the actual value of real voltage. Result is in [V].
READ: I 2: CURR?	Reads the actual value of real current. Result is in [A].
READ: I 2: RES?	Reads the actual value of real resistance. Result in [Ω].

High Voltage Test (H1)

CONF: H1: TIME <test time> ?	Sets the test time: range 0.1 - 999.0, default 5.0 [s].
CONF: H1: CON: SOCK PROB ?	Selects the connection type of tested device: SOCK – socket (for devices of safety class 1), default PROB – test probe
CONF: H1: TMODE: TEST NEND ?	Sets the test method: TEST – normal test, default NEND – testing without any time limit (test has to be aborted explicitly)
CONF: H1: SKTYP: OFF IMP HOLD ?	Selects the starting mode: OFF – test starts immediately IMP – test is started by an impulse applied to the digital input defined by SKI NP (see below), default HOLD – test is started by a signal on the defined digital input. Signal must apply during the whole test.
CONF: H1: SKI NP <input nr.> ?	Safety contact: specifies the number of the digital input by which the command SKTYP checks the status of safety contact. <input nr.> is in range 1-16 (1-8 = external inputs, 9-16 = internal inputs).
CONF: H1: DEF	Resets all parameters for the High Voltage Test (H1) to their default values.
MEAS: H1	Starts the High Voltage Test (H1) with a fixed voltage of 1500 V DC.
READ: H1: VOLT?	Reads the actual value of real voltage. Result is in [V].
READ: H1: CURR?	Reads the actual value of real current. Result is in [A].

High Voltage Test (H2)

CONF: H2: TIME <test time> ?	Sets the test time: range 0.1 - 999.0, default 5.0 [s].
CONF: H2: RAMP <ramp time> ?	Sets the time of voltage ramp at the beginning and (optionally) at the end of a test: range 0.0 - 999.0, default 1.0 [s].
CONF: H2: RDWN: ON OFF ?	Chooses whether to use the ramp-down feature or not: OFF - voltage ramp at test's end disabled (default) ON - voltage ramp at test's end enabled
CONF: H2: USTART <U start> ?	Sets the starting (resp. ending) value for the voltage ramp at a test's beginning (resp. ending). General range is 0 - 6000, default 0 [V]. However this value must be smaller than or equal to <U nom>.
CONF: H2: UNOM <U nom. > ?	Sets the nominal test voltage: general range is 100-6000, default 500 [V]. The real upper limit is either 3000, 4000 or 6000 V, depending on the device variant.
CONF: H2: I MAX <I max. > ?	Sets the upper limit for real current during the test. Throughout the test, the measured current is constantly compared with this value. If the measured value exceeds the limit, the test is aborted with error status = 130. The upper limit depends on the device type, resp. on the used type of generator (2, 4 or 10 mA). Min. value = 0 A, default value = maximum generator current. Value is specified in [A].
CONF: H2: I RMIN <I min. > ?	Sets the lower limit for real current during the starting ramp (not used during ending ramp). During the ramp, the measured current is compared with this value. If the measure is below the threshold, the test is aborted with error status = 136. The upper limit depends on the device type, resp. on the used type of generator (2, 4 or 10 mA). Min. value = 0 A, default value = 0 A. Value is specified in [A]. If this parameter is set to 0, or if the parameter RERR is set to EXTRA, the checking of minimal current is disabled.
CONF: H2: I RMAX <I max. > ?	Sets the upper limit for real current during ramp, if parameter RERR is set to EXTRA. The current measured during ramp-up and ramp-down is compared to this value. If the threshold is exceeded, the test is aborted with error status = 130. The maximum upper limit depends on the device type, resp. the used generator (2, 4 or 10 mA). Min. value = 0 A, default value = max. generator current This value is specified in [A].

CONF: H2: RERR: NORM EXTRA MBE ?	<p>Specifies how to check current during ramp:</p> <p>NORM – Real current during ramp up and down is checked against IMAX (same limit as during test time), default</p> <p>EXTRA – The extra value IRMAX is used as upper limit during ramp up and down. Also the lower limit IRMIN is checked (only during ramp up), if it is set greater than zero.</p> <p>MBE – The maximum allowed current for ramp-up is same as the generator's upper limit (2, 4 or 10 mA, depending on device type). During ramp-down, IMAX is used as upper limit. If the thresholds are exceeded, test is aborted with status = 130.</p>
CONF: H2: ARC <param.> ?	<p>Sets the maximal allowed signal disturbance. The value specifies the percentage (%) of tolerance in relation to the nominal voltage or maximum current.</p> <p>The details of parameter use will be specified later and than it will be added in devices.</p>
CONF: H2: CON: SOCK PROB SK2 ?	<p>Sets the method of DUT connection:</p> <p>SOCK – socket (for devices of safety class 1), default</p> <p>PROB – test probe</p> <p>SK2 – socket (for devices of safety class 2)</p> <p>Mode SK2 is available only in some devices (see the list GerätespezMenü.xls).</p>
CONF: H2: METH: SOUR SENS ?	<p>Sets the method of voltage measurement:</p> <p>SOUR – 2-wire method</p> <p>SENS – 4-wire method, default</p> <p>This command is available only in IL3801 devices.</p>
CONF: H2: TMODE: TEST BURN NEND ?	<p>Selects the starting mode:</p> <p>TEST – normal test, default</p> <p>NEND – testing without any time limit (test has to be aborted explicitly)</p>
CONF: H2: SKTYP: OFF IMP HOLD ?	<p>Wählt den Startmodus:</p> <p>OFF – test starts immediately</p> <p>IMP – test is started by an impulse applied to the digital input defined by SKI NP (see below), default</p> <p>HOLD – test is started by a signal on the defined digital input. Signal must apply during the whole test.</p>
CONF: H2: SKI NP <input nr.> ?	<p>Safety contact: specifies the number of the digital input by which the command SKTYP checks the status of safety contact. <input nr.> is in range 1-16 (1-8 = external inputs, 9-16 = internal inputs).</p>
CONF: H2: DEF	<p>Resets all parameters for the High Voltage Test (H2) to their default values.</p>

MEAS: H2	Starts the High Voltage Test (H2).
READ: H2: UGEN?	Reads the value of output voltage from generator (source value). When 2-wire-method is selected, this command returns the same value as READ:H2:VOLT? Result is in [V]. <i>This command is available only in IL3801 devices.</i>
READ: H2: VOLT?	Reads the actual value of real voltage. Result is in [V].
READ: H2: CURR?	Reads the actual value of real current. Result is in [A].

DISP Commands

DI SP: ROW1 <text>	Shows the text <text> in the specified row of the device-displays. The text string must be enclosed in quotation marks ("). Maximum string length is 20 characters. A string of zero length ("") will clear the specified display row.
DI SP: ROW2 <text>	
DI SP: ROW3 <text>	
DI SP: ROW4 <text>	
DI SP: CLS	Clears all rows of the device display.

SYST Commands

SYST: HALT	Aborts any running test.
SYST: PASS: ON OFF	Switches the green signal lamp on/off, or shows/clears the green PASS rectangle on the display.
SYST: FAI L: ON OFF	Switches the red signal lamp on/off, or shows/clears the red FAIL rectangle on the display.
SYST: BEEP: SOFT LOUD	Activates the buzzer for 100ms. ("SOFT" is only available for series 3300 and 2200 devices.)
SYST: AI NP <AI nr. >	Reads analog input nr. = <AI nr.>. The value of <AI nr.> must be in 2 digits. The answer value is in range 0.000 - 9.999 [volts]. Notice: The IL 3801 has 2 analog inputs so the <AI nr.> can be 01 or 02.

A-5 Status and error parameters

Command Version

Depending on the type variant, devices IL 3801 have a different range of test functions.

By means of the command *VER? one can read the "Version ID", indicating the exact device type.

Device type	Version ID	Continuity Test	Protective Wire Test	Insulation Test	High Voltage Test	Function Test	Visual Test (1)	Digital inputs (2)	Digital outputs (3)
IL3801F	758	CT	—	I2	H2	—	(VT)	(RI)	(SO)
IL3881G	759	CT	—	I2	H2	—	(VT)	(RI)	(SO)

- (1) Visual Test is done directly by remote PC, through test steps "Text Visual Test" and "Picture Visual Test".
(2), (3) Digital Input and Output steps are realized through the global commands *INP, *INPW und *SET.

Device mode (operating mode)

Describes the operating mode the device actually is in.

This value can be read by the command *MOD? .

Bit position	B7	B6	B5	B4	B3	B2	B1	B0
Meaning	<u>Control type</u>			<u>Communication</u>			<u>Remote mode</u>	

	Hex ¹⁾	bin	Dez ¹⁾
<u>Control type</u>			
Manual	\$00	000 xx xxx	0
Automatic	\$20	001 xx xxx	32
Digital	\$40	010 xx xxx	64
<u>Communication</u> ²⁾			
RS-232	\$00	xxx 00 xxx	0
USB	\$08	xxx 01 xxx	8
Ethernet	\$10	xxx 10 xxx	16
<u>Remote mode</u> ²⁾			
Test is running	\$00	xxx xx 000	0
Programmes exchange	\$01	xxx xx 001	1
Results exchange	\$02	xxx xx 010	2

¹⁾ The decimal and hexadecimal values represent the sum of the relevant bit block.

²⁾ "Communication" and "Remote mode" are only relevant in operating mode "automatic".

Status register

At every moment, the status register contains a bit pattern describing the current device activity.

This value can be read by the command `*STA?` .

Bit position	B7	B6	B5	B4	B3	B2	B1	B0
Meaning	<u>Activity</u>				<u>Test end</u>			

Zustand	hex	bin	dez
<u>Activity</u>			
Idle state	\$00	0000 0000	0
Test starts	\$10	0001 0000	16
Test preparing	\$20	0010 0000	32
Ramp up *	\$30	0011 0000	48
Measuring	\$60	0110 0000	96
Ramp down *	\$50	0101 0000	80
Test ending	\$40	0100 0000	64
Test finished	\$80	1000 0000	128
<u>Test end</u>			
STOP button	\$81	1000 0001	129
HV test – high current	\$82	1000 0010	130
PW test – start timeout	\$83	1000 0011	131
PW test – disconnected	\$84	1000 0100	132
SK – safety control released	\$85	1000 0101	133
<i>LC-Test – high current</i>	<i>\$86</i>	<i>1000 0110</i>	<i>134</i>
<i>Extension failed</i>	<i>\$87</i>	<i>1000 0111</i>	<i>135</i>
HV-Test – low current	\$88	1000 1000	136
After SYST:HALT	\$8F	1000 1111	143
<i>* only if supported by device variant</i>			

'Test end type' bits has meaning only if it is set the 'Activity' bits to 'Test finished'.

'HW breaks' bits are contains detailed information why test was interrupted from device.

- "stop button" - pressed the stop button on the device.
- "HV test - high current" - measured current is higher than maximal current in Insulation Test I2, I3 or in High Voltage Test H2 or H3. Current limit is sent to device on the test begging.
- "PW test - start timeout" occurs in the Protective Wire Test when the nominal current does not appear in 5 seconds after test start.
- "PW test - disconnected" occurs in the Protective Wire Test immediately when the measuring current was broken during the test.
- "SK control released" - the safety contact was released during test (if parameter SKTYP was set to HOLD).
- "LC test - high current" occurs in the Leakage Current Test (available only with EW3301 extension unit) immediately when the measured current exceeds the maximal limit sent to device before test start. It used only in 3300 series.
- "extension failed" occurs in device with extension when extension was switched off or when the communication with it does not work. It used only in 3300 series.
- "HV test - low current" occurs in High Voltage Test H2, H3 if it is activated the checking of the minimal current during the ramp up and the real current is less than min. value sent to device (parameter IRMIN).
- "After SYST:HALT" - the test was broken by command SYST:HALT from remote PC.

Error status

Below table shows the explanations for the error codes that can be read from the error queue by means of the command *ERR? :

Number	Error description
200	Queue overflow
0	No error
2	Missing end character
3	Wrong command
4	Wrong MEAS parameter
5	Wrong CONF parameter
6	Wrong SYST parameter
7	Wrong READ parameter
8	Wrong DISP parameter
9	Unable to start measurement

B Interface Configuration

B-1 External I/O Interface X6

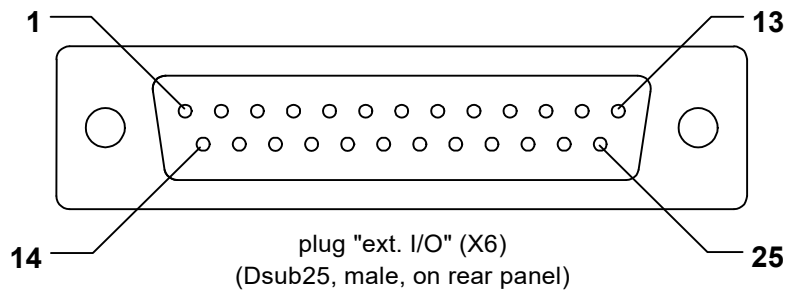

PIN	description	configuration
1	output 1	EXT_PASS
2	output 2	EXT_FAIL
3	output 3	EXT_BUZZER
4	output 4	EXT_TEST (active during complete test)
5	output 5	<i>not used</i>
6	output 6	<i>not used</i>
7	output 7	<i>not used</i>
8	output 8	<i>not used</i>
9	analog input 1 ¹⁾	
10	—	<i>not used</i>
11	input 1	4 bit program selection (2 ⁰)
12	input 2	4 bit program selection (2 ¹)
13	input 3	4 bit program selection (2 ²)
14	input 4	4 bit program selection (2 ³)
15	input 5	<i>not used</i>
16	input 6	EXT_ACK
17	input 7	<i>not used</i>
18	input 8	EXT_START
19	—	<i>not used</i>
20	+24 V DC	feed-in ext. voltage against ground ²⁾
21	+24 V DC	feed-in ext. Voltage against ground ²⁾
22	analog input 2 ¹⁾	
23	—	<i>not used</i>
24	GNS	grounding
25	GNS	grounding

¹⁾ potential separated from internal supply

²⁾ has to be fed in from external

Description of most important signals on I/O interface:

Inputs:

- 6 EXT_ACK - interrupts a running test
- accepts a faulty measurement
- 8 EXT_START - starts a test run
- repeats test after a faulty measurement
- 1-4 4 bit program selection - deals for remotely selecting the test program.

The 4 bit of digital program selection specify the test program to be activated by the start signal .

A total of 16 different programs can be addressed, where the number of a program equals to the program's position in the list of test programs. The 4 inputs $2^0 - 2^3$ specify the offset added to the first program.

Example:

$$2^0 = 0 ; 2^1 = 1 ; 2^2 = 1 ; 2^3 = 0 \Rightarrow 0 + 2 + 4 + 0 = 6$$

Here, the 6th program from the list is selected, loaded and run.

Outputs:

- 1 EXT_PASS - is set when a test result "pass" is achieved, stays active until EXT_TEST is set again.
- 2 EXT_FAIL - is set when a test result "fail" is achieved, stays active until EXT_TEST is set again.
- 3 EXT_BUZZER - is set same as the device's built-in buzzer
- 4 EXT_TEST - is set together with the first start signal, stays active during whole test run.

Basic circuit for I/O interface X6:

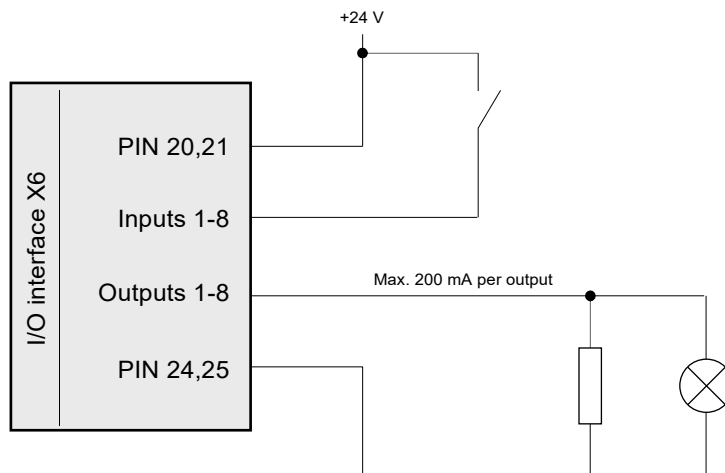

Digital Control over the Interface "Ext. I/O"

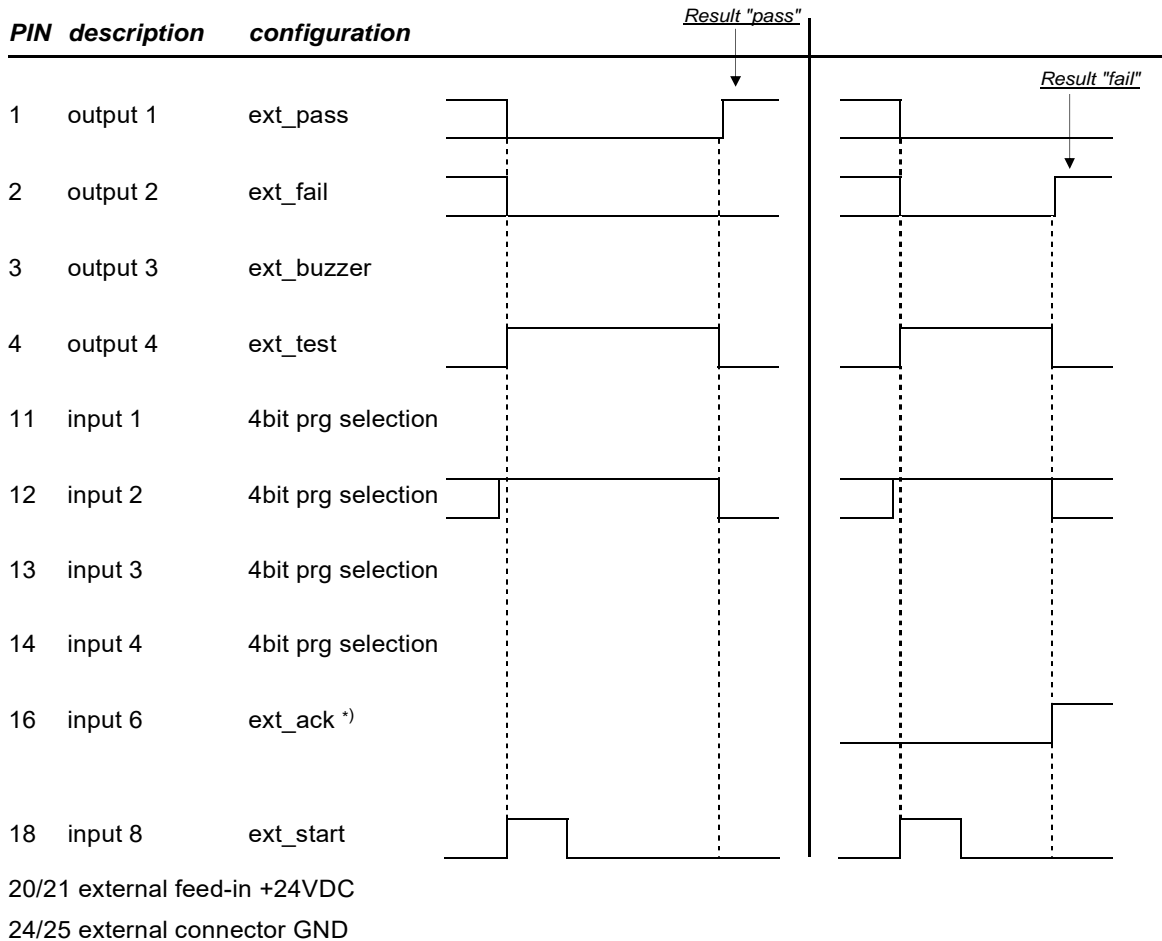

To repeat a faulty test step, one must

- Give no signal ACK but a new signal START *or*
- Set signal START to "low" and then to "high" again

In order to be detected, the impulses for ACK and START must have a minimum duration of 50 ms.

*) In the system parameters, it can be configured if faulty tests have to be quitted by a signal ACK.

When this option is set, in case of a faulty test the following message appears:

Waiting for external **QUIT**T

B-2 Serial RS-232 Interface X1

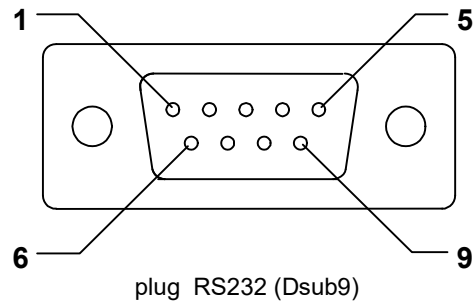

PIN	description	configuration
1	—	<i>not used</i>
2	RxD	Receive Data
3	TxD	Transmit Data
4	—	<i>not used</i>
5	mass	Reference potential of serial interface
6	—	<i>not used</i>
7	—	<i>not used</i>
8	—	<i>not used</i>
9	—	<i>not used</i>

Interface configuration: according to system settings (see chapter 5.9.1, page 38)
 Standard: 9600 baud, 8 data bits, 1stopbit, no parity.

B-3 Second external I/O Interface X13 (only IL 3881)

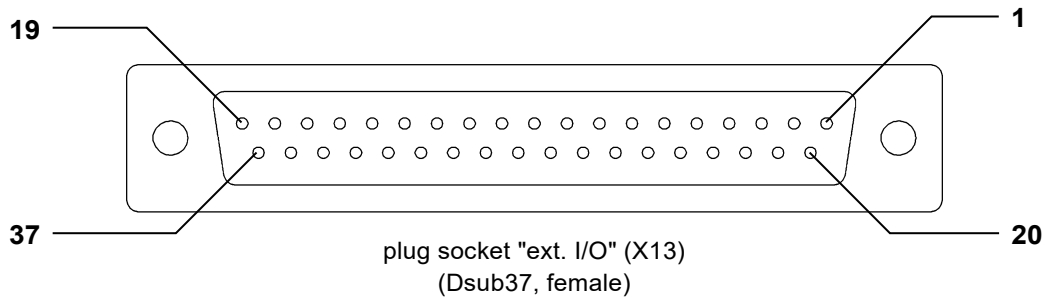

PIN	Bezeichnung	Belegung
1	output 1	<i>not used</i>
2	output 3	<i>not used</i>
3	output 5	<i>not used</i>
4	output 7	<i>not used</i>
5	output 9	<i>not used</i>
6	output 11	<i>not used</i>
7	output 13	<i>not used</i>
8	output 15	<i>not used</i>
9	input 1	<i>not used</i>
10	input 3	<i>not used</i>
11	input 5	<i>not used</i>
12	input 7	<i>not used</i>
13	input 9	<i>not used</i>
14	input 11	<i>not used</i>
15	input 13	<i>not used</i>
16	input 15	<i>not used</i>
17	+24 V DC	voltage against mass ^{*)}
18	Gnex	grounding
19	Gnex	grounding
20	output 2	<i>not used</i>
21	output 4	<i>not used</i>
22	output 6	<i>not used</i>
23	output 8	<i>not used</i>
24	output 10	<i>not used</i>
25	output 12	<i>not used</i>
26	output 14	<i>not used</i>
27	output 16	<i>not used</i>
28	input 2	<i>not used</i>
29	input 4	<i>not used</i>
30	input 6	<i>not used</i>
31	input 8	<i>not used</i>
32	input 10	<i>not used</i>
33	input 12	<i>not used</i>
34	input 14	<i>not used</i>
35	input 16	<i>not used</i>
36	+24 V DC	voltage against mass ^{*)}
37	GNex	grounding

^{*)} internally generated (not needed to be fed in externally)

Basic circuit for interface X13:

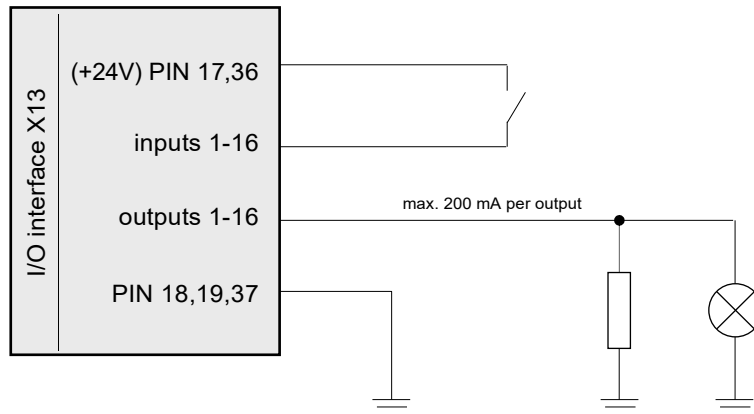

B-4 Rear panel connector for test voltages (only IL 3881)

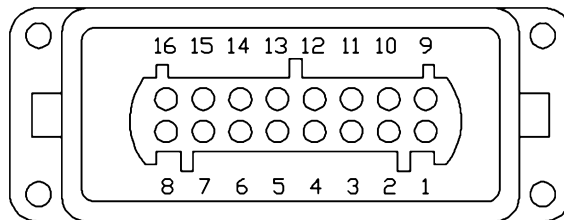

industrial socket, 16-pole

PIN	description	configuration
1	l	source+ (positive pole of High Voltage) / line (+) for Continuity Test
2	—	not used
3 *)	pe	source- (negative pole of High Voltage)
4 *)	pe	source- (to PIN3)
5	—	not used
6	pe'	sense- (4-wire technique: measurement of HV-)
7	—	not used
8	(start*)	not used
9	n	sense+ (4-wire technique: measurement of HV+) / line (-) for Continuity Test
10	—	not used
11	(probe')	not used
12	—	not used
13	(probe)	not used
14	(probe)	not used
15	—	not used
16	(start)	not used

*) The PINs 3 + 4 (pe) must be bridged.

C LAN Operation – Setup and Procedure

C-1 LAN Operation

Setup

(Addresses are examples)

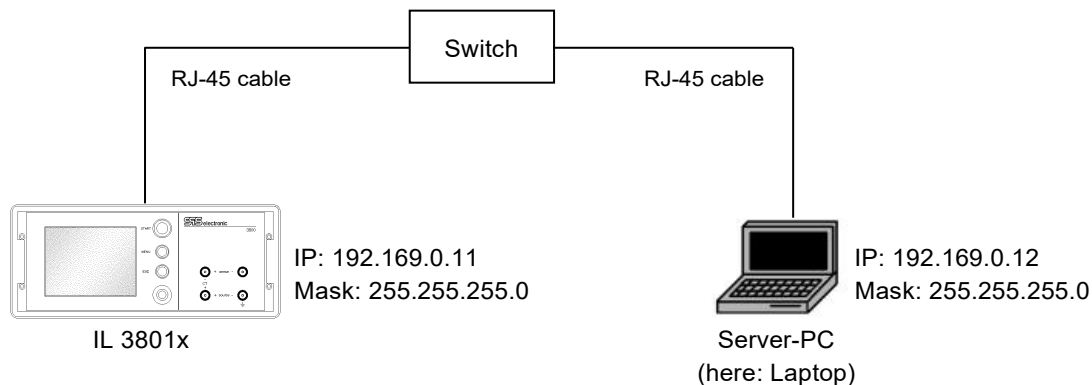

Description

The device IL3801x is connected to the server PC via a LAN-Switch and RJ-45 cables.

The IL 3801x has to be configured in

Main menu → System parameters → Interfaces → Ethernet

Local IP: **192.169.0.11** (IP address of the tester)
 Server IP: **192.169.0.12** (server IP address. If there's already one allocated, that one can be used.)
 Server port: **23**
 Gateway: **192.169.0.12** (same IP as server IP)
 Mask: **255.255.255.0**

The server PC gets configured with IP address **192.169.0.12** and mask **255.255.255.0**.

All assigned static IP addresses must be located in the same subnet.

In case that devices are located in different subnets, a gateway has to be configured, that connects the different subnets.

Test procedure

- The application DAT3332 is started on the server PC, and a custom test programme is created. This test programme then is saved as e.g. "Test.prg" in the PRG folder of the 3800NET software.
- Start the application 3800NET. Call "Tools" → "Productlist". By "Add..." a new article number or name is created (here: "ISO"). Then click on "search" and load the formerly created "Test.prg". Confirm with "OK".
- The device IL3801x has to be set to operating mode "Ethernet":
 Main menu → System parameters → operating mode → Ethernet → "activate"
 ⇒ After activation, the connection to the server PC is established.
- At the IL3801, a request for "ISO" is made (e.g. by barcode) The device sends the request to the server.
- Server sends the needed programme back to the device. After reception, the IL3801x starts the test.
- After test has finished, the IL3801 sends the test results to the server PC. There, the results are stored in the specified data base.

C-2 WLAN Operation

I. Setup (Ad-Hoc Operation)

(Addresses are examples)

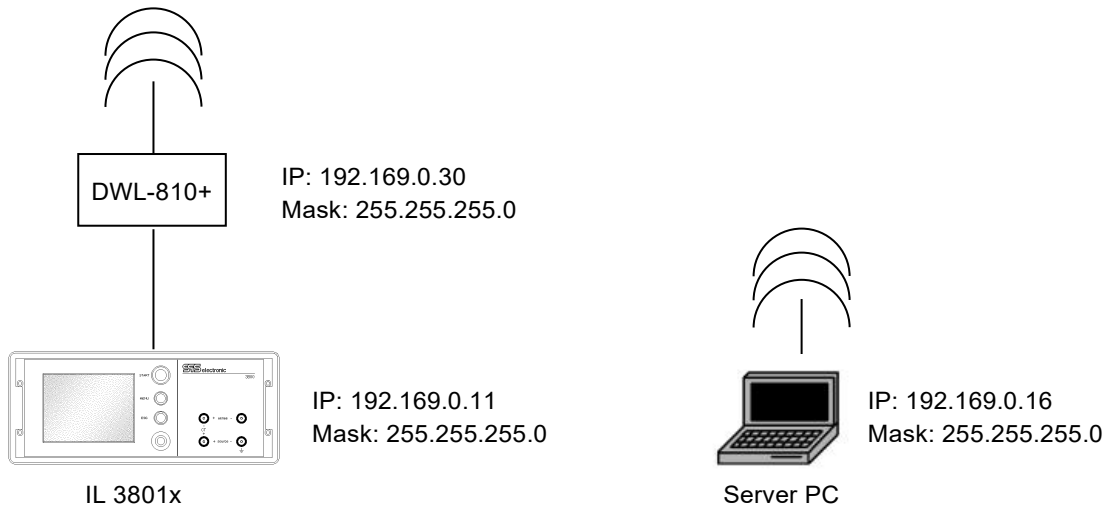

Description

The device IL 3801x is connected to a WLAN converter (e.g. DWL-810+) via an RJ-45 cable.

The IL 3801x has to be configured in

Main Menu → System parameters → Interfaces → Ethernet

Local IP: **192.169.0.11**
 Server IP: **192.169.0.16**
 Server port: **23**
 Gateway: **192.169.0.16** (selbe IP wie Server-IP)
 Mask: **255.255.255.0**

- The DWL-810+ gets configured with IP address **192.169.0.30** and mask **255.255.255.0**.
- The server PC gets configured with IP address **192.169.0.16** and mask **255.255.255.0 (WLAN)**.

All assigned static IP addresses must be located in the same subnet.

If the server PC uses an external WLAN adapter, then the adapter must be configured with its own IP address, different from the server's IP address. In the ethernet configuration of the IL3801 device, one has to enter the IP address of the adapter, not the server's one.

Test procedure

- The application 3332DAT is started on the server PC, and a custom test programme is created. This test programme then is saved as e.g. "Test.prg" in the PRG folder of the 3800NET software.
The path to the folders of 3800NET is set as follows:
In the 3332DAT software, go to:
Options / Environment / Pathnames
There, in the first line, the path to "test program folder (*.prg)" must be set to
C:\Program files\SPS electronic\3800net\PRG\
After having made this setting, all test programmes created with 3332DAT's program editor will be saved in the PRG folder of 3800NET.
- Start the application 3800NET. Call "Tools" → "Productlist". By means of "add", create a new article number or name (here: ISO). Then press "Browse..." and select the previously created test programme (here: "Test.prg").
Confirm with "OK".
- The IL 3801x has to be set to operating mode "Ethernet" by
Main menu → System parameters → Operating mode → Ethernet → "aktivate"
⇒ After activation, the connection to the server PC is established.
- At the IL3801x, a request for "ISO" is made (e.g. by barcode). The device sends the request to the server.
- Server sends the needed programme back to the device. After reception, the IL3801x starts the test.
- After test has finished, the IL3801x sends the test results to the server PC. There, the results are stored in the specified data base.

II. Setup (Infrastructure operation)

(Addresses are examples)

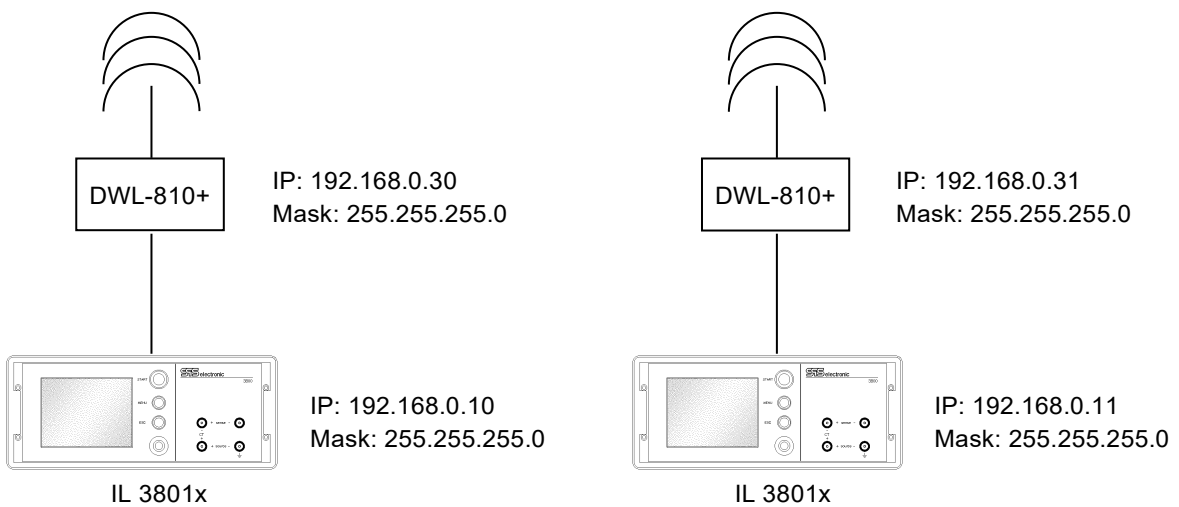
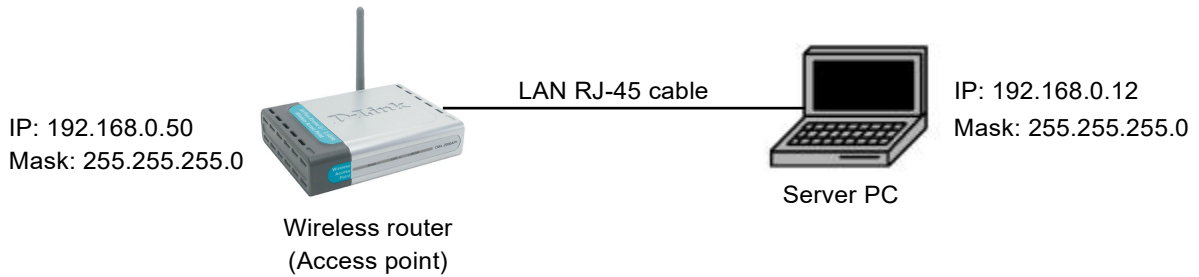

Description

Each IL 3801x is connected to a WLAN converter (e.g. DWL-810+) via RJ-45 cable.
All devices IL 3801x must be configured in

Main menu → System parameters → Interfaces → Ethernet

as follows:

IL 3801x 1:	IL 3801x 2:	IL 3801x 3:
Local IP: 192.168.0.10	Local IP: 192.168.0.11	Local IP: 192.168.0.13
Server IP: 192.168.0.12	Server IP: 192.168.0.12	Server IP: 192.168.0.12
Server port: 23	Server port: 23	Server port: 23
Gateway: 192.168.0.50 (IP of access point)	Gateway: 192.168.0.50 (IP of access point)	Gateway: 192.168.0.50 (IP of access point)
Mask: 255.255.255.0	Mask: 255.255.255.0	Mask: 255.255.255.0
DWL-810+	DWL-810+	DWL-810+
IP address: 192.168.0.30	IP address: 192.168.0.31	IP address: 192.168.0.33
Mask: 255.255.255.0	Mask: 255.255.255.0	Mask: 255.255.255.0

etc.

The server PC gets configured with IP address **192.168.0.12** and mask **255.255.255.0** (LAN).

The access point (DWL-2000AP+) gets configured with IP address **192.168.0.50** and mask **255.255.255.0**.

All assigned static IP addresses must be located in the same subnet.

The adapters DWL-810+ must be configured for infrastructure operation, and to an existing "Remote AP-MAC".

Test procedure is the same as described in ad-hoc operation.

D Description of Test Methods

D-1 Continuity Test

To ascertain that the DUT is both switched on and contacted correctly, the current of a current limited 22V / 0.5A direct current source is measured between L and N.

The current which appears during measurement depends on the internal resistance of the DUT and can only be determined with the test system.

D-2 Insulation Test

The insulation resistance between current-carrying lines and the protective wire is measured by means of the insulation test. The test voltage and max. short circuit current depend on the type of testing device being used.

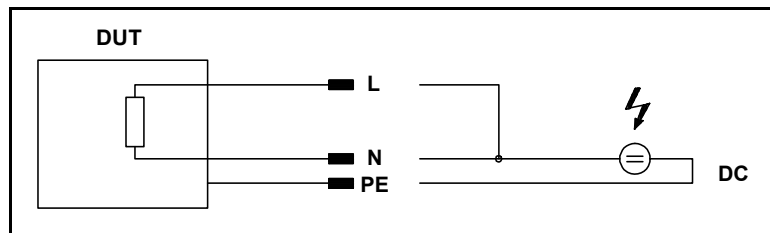

Basic circuit for Insulation Test

D-3 High Voltage Test

The high voltage test DC tests the electric strength between current-carrying lines and the protective wire (or between HV-pistol / test probe and protective wire resp.) (bzw. zwischen HV-Pistole/Prüfsonde und Schutzleiter). If supported by the device type, the HV-AC test can be performed with a programmed voltage ramp.

If DUT's insulation is damaged or insufficient, an arc-over will occur.

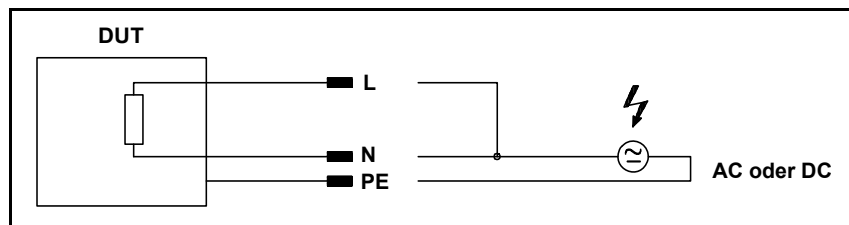

Basic circuit for high voltage test

E USB devices, and "Testing with High Voltage"

- When testing with high voltage, a failing testpiece can be the cause for electromagnetic radiation (because of voltage arc-over at the weak point in the testpiece), and the resulting sparking can cause EM radiation of high frequencies. This radiation gets emitted by the test lines – antenna principle – , and may get received again by USB lines in the closer surrounding.
- USB controllers are generally vulnerable to stray fields of high frequencies, and thus the communication with USB can get interrupted. In particular, it is possible that short occurrences of stray fields put the USB-controller into a persistent inoperable state, so that USB communication keeps being interrupted.
- If such an USB malfunction occurs, often it is already sufficient to just unplug the USB cable, and plug it in again after a few seconds. If the malfunction still persists, it is needed to switch the affected devices off, and on again.

Concerned Situations and devices:

- generally every kind of PC or similar device that is using a USB connection, and is located in very close neighborhood to a test with high voltage.
- in particular such PCs that are using DAT3800 or DAT1800 software to control a testing device, and are using an USB connection to the test device.
- also test devices of series 3800 or 1800, when they are themselves using external USB devices, like e.g. USB keyboard, USB barcode scanner, or USB sticks for data exchange.

Measures to avoid failures

- as far as possible, it is recommended to keep a sufficiently large distance between USB cables/devices, and testpiece / testing lines. (Recommended are at least 30cm, the practical rule is "the more, the better".)
- it is recommended to use well-shielded USB cables with ferrite-core coil.
(On its own this won't eliminate the possibility of errors, but it generally reduces sensitivity against stray fields, and makes occurrence of errors less likely.)

Your notes

Your notes

EU-Konformitätserklärung

EU Declaration of Conformity

Wir / we :

SPS electronic GmbH
The Electrical Safety Test Company
Eugen-Bolz-Straße 8
D-74523 Schwäbisch Hall

erklären hiermit, dass das nachfolgend genannte Gerät den einschlägigen grundlegenden Sicherheitsforderungen der EU-Richtlinien entspricht.

declare, that the following unit complies with all essential safety requirements of the EU Directives.

Geräteart:

Isolations- und Hochspannungsprüfgerät
Insulation- and High Voltage Tester

Description of device:

Typ / Type :

IL 3801 / 3881 F/G

EU Richtlinien / EU Directives:



EG Maschinenrichtlinie 2006/42/EG mit Änderungen
EC Directive for machinery 2006/42/EC with amendments



EU Niederspannungsrichtlinie 2014/35/EU
EU Directive for low voltage 2014/35/EU



EU Richtlinie Elektromagnetische Verträglichkeit 2014/30/EU mit Änderungen
EU Directive electromagnetic compatibility 2014/30/EU with amendments

Angewandte harmonisierte Normen:

Applicable harmonized standards:

- EN 61 000-3-2; EN 61 000-3-3; EN 55 014-1; EN 55 014-2; EN 50 191

Angewandte nationale Normen und technische Spezifikationen:

Applicable national standards and technical specifications:

30.06.2017

Datum / date:

SPS electronic
SPS electronic GmbH
Blätteräcker 18 • 74523 Schwäbisch Hall-Sulzdorf
Telefon 0 79 07 / 878-0 • Fax 0 79 07 / 878-99

ppa. Dipl. Ing. Stefan Ruhl

Dieser Konformitätserklärung unterliegt grundsätzlich nur das von uns gelieferte oder in Betrieb genommene Gerät. Für Änderungen und Erweiterungen ist der Betreiber verantwortlich und damit für die Sicherstellung der Übereinstimmung der veränderten Anlage mit der betreffenden EU-Richtlinie.

Subject to this declaration of conformity is the device as supplied or placed into operation by us.

The operator is responsible for subsequent alterations and extensions, and therefore has to ensure the altered unit complies with the corresponding EU directives.